

## DESIGN, FABRICATION, CALIBRATION AND VALIDATION OF A NINE HOLE PROBE FOR MEASUREMENT OF FLOW WITH LARGE ANGLES

N. Sitaram  
Turbomachines Laboratory  
Department of Mechanical Engineering  
Indian Institute of Technology Madras  
Chennai-600 036, India  
*Present Address* : School of Aeronautical Sciences  
Hindustan Institute of Technology and Science  
No.1, Rajiv Gandhi Salai (OMR), Padur  
Kelambakkam (Via), Chennai-603 103, India  
Email : nsitaram.iitm@gmail.com

M. Venkatesh Babu  
Turbomachines Laboratory  
Department of Mechanical Engineering  
Indian Institute of Technology Madras  
Chennai-600 036, India  
*Present Address* : Flat No. 616  
MVV Ozone Apartment  
Midhilapuri Vuda Colony  
PM Palem, Madhurawada  
Visakhapatnam-530 041, India

### Abstract

*The design and fabrication details of a nine hole pressure probe for measurement of flow with large angles are presented. The probe is calibrated at a velocity of 40 m/s in a yaw range of  $\pm 90^\circ$  and a pitch range of  $-70^\circ$  to  $90^\circ$  at intervals of  $10^\circ$ . The calibration space is divided into 9 zones, in each of which pressure from one of the nine holes is maximum. Calibration coefficients based on the pressures from this hole and other holes around this hole are defined in each of these zones. Additional data acquired during the calibration are used to validate the data reduction method. The errors in total and static pressures and flow velocity and angles are found to be small.*

**Keywords:** *Nine Hole Pressure Probe, Non-nulling Calibration, Large Angles, Zonal Method*

### Nomenclature

$C_{PPITCH}$	= Pitch angle coefficient of the probe
$C_{PSTATIC}$	= Static pressure coefficient of the probe
$C_{PTOTAL}$	= Total pressure coefficient of the probe
$C_{PYAW}$	= Yaw angle coefficient of the probe
$D$	= Probe dynamic pressure ( $N/m^2$ )
$P_M$	= Average of pressure ( $N/m^2$ )
$P_O$	= Total pressure ( $N/m^2$ )
$P_S$	= Static pressure ( $N/m^2$ )
$P_1$ to $P_9$	= Probe pressures in Zones 1 to 9 ( $N/m^2$ )
$Q$	= True dynamic pressure = $P_O - P_S$
$\alpha$	= Yaw angle (deg)
$\beta$	= Pitch angle (deg)
$\Delta$	= Interpolation error

### Subscripts

in = Interpolated value

### Introduction and Objective

Five hole [1] and seven hole [2] probes are extensively used for measurement of total and static pressures, flow angles, velocity and its components in turbomachinery and other fluid flows. However their operating range is usually limited to  $40^\circ$  and  $60^\circ$  respectively, although various techniques are devised to extend the range upto about  $70^\circ$  [3]. However in many flows the variation of angles may be  $90^\circ$  or more. Hence there is a need to develop a probe which can be used to measure flow with large angles. One such probe is omni direction probe [4], which can measure flows with very large angles, upto  $150^\circ$ . The probe consists of 12 or 18 holes strategically placed on a sphere. However the smallest omni directional probe available has a head of 6.35 mm dia., with pressure measuring holes of 0.35 mm dia. and pressure take-off tubes of

0.5 mm dia. Hence its usefulness in turbomachinery flows is limited because of large spatial errors. Hence there is a need to develop a probe (3 to 4 mm dia.) which can measure flows with large angles upto  $90^\circ$  or more. This is the objective of the present investigation. As a first step to achieve the objective a nine hole probe with a head diameter of 8 mm dia. is fabricated. The large size is chosen because of limitations in machine shop. After calibration of the probe and validating the probe, a smaller nine hole probe will be fabricated using CNC machining by an external agency. The paper discusses design strategy, fabrication and calibration details of the nine hole probe. The paper also gives details of the data reduction method to extract pressures, velocities and flow angles from the probe measurements.

### Design and Fabrication Details of the Probe

AUTOCAD drawing of the probe head is shown in Fig.1. The probe head is a hemisphere with flat surfaces from  $30^\circ$  to  $60^\circ$  (at an angle of  $45^\circ$ ) and from  $60^\circ$  to  $90^\circ$  (at an angle of  $75^\circ$ ) to reduce Reynolds number effects. The probe head has a diameter of 8 mm and length of 10 mm. The probe head is made from stainless steel. Nine holes of 0.6 mm diameter are drilled on the surface of the probe head. These holes are connected to the pressure take off holes of 1.3 mm diameter at the end of the probe head. One of the holes (9) is at the centre of the head and is mainly responsive to the total pressure. One pair of the holes (1 and 5) is located on the pitch planes and another pair of holes (3 and 7) is located on the yaw plane. These holes make an angle of  $45^\circ$  with the centre of the hemisphere. Another set of four holes (2, 4, 6 and 8) make an angle of  $75^\circ$  with the center of the hemisphere. These four holes are staggered at an angle of  $45^\circ$  to the holes 1, 3, 5 and 7. These holes are responsive to both pitch and yaw angles. To avoid mating of holes, a minimum clearance of 0.5 mm is kept between the holes. Stainless steel tubes of 1.3 mm diameter are soldered to the inside of these nine holes at the base of the probe head. A sleeve of inner diameter of 8 mm and with a tapered outer diameter from 8.2 mm to 9.5 mm over a length of 35 mm is soldered to the probe head. A probe support of 9.5 mm outer diameter tube is soldered to this sleeve.

### Calibration Tunnel, Calibration Device and Instrumentation

The probe is calibrated in the open jet calibration tunnel of Turbomachines Laboratory, Department of Mechanical Engineering, IIT Madras at a velocity of 40 m/s

in a yaw range of  $\pm 90^\circ$  and a pitch range of  $-70^\circ$  to  $90^\circ$  at intervals of  $10^\circ$ . Although step motors are available on the calibration device, the probe pitch and yaw angles are changed manually. The limitation on the  $-70^\circ$  for the pitch angle is due to the interference between the probe support and the calibration duct. The pressures from the probe and the static pressure on the contraction inlet are measured using a 20 channel single scanning box (Model FCO 91-3) and a digital micromanometer (FC012) manufactured by Furness control Ltd., Bexhill, London. The static pressure is atmospheric. The scanning box has twenty channels, which are numbered sequentially. The pressures to be measured are connected to the numbered inputs. The outlet channel is connected to the micro manometer. A particular channel is selected manually in the scanning box and its corresponding pressure can be digitally read from the micro manometer. The micro manometer used is sensitive to differential air pressure with a resolution of 0.1 mm water column. The range of the micromanometer is  $\pm 200$  mm of water column. The resolution of the micro manometer is  $\pm 0.1$  mm of water column. The accuracy claimed by the manufacturer is  $\pm 0.5\%$  of full scale. The output of the scanning box is connected to the micro manometer and it gives reading directly in terms of velocity in m/s or pressure in mm of water column. Time constant potentiometer is used to measure time-averaged pressures.

### Calibration Procedure and Sample Data

#### Calibration Procedure

The calibration of the probe consists of aligning the probe in reference pitch and yaw directions. The probe is fixed horizontally giving the reference pitch angle of zero degree. The probe is rotated about its yaw axis so that the pressures from the holes 3 and 7 of the probe are equal giving the reference yaw angle of zero degree. Then the calibration of the probe is preceded in following way.

At each combination of yaw and pitch angles, the probe pressures are measured at a constant velocity of 40 m/s. The yaw angle is kept constant and the pitch angle is changed in an interval of  $10^\circ$  in the range of  $-70^\circ$  to  $90^\circ$ . Then the yaw angle is changed by  $10^\circ$  and the calibration is carried out in the range of  $\pm 90^\circ$ . Additional data are acquired during calibration; these data are used to validate the data reduction method.

The variation of pressures from the different holes is presented in Figs.2 to 4. Contours of non-dimensional

pressure of centre hole (9) for different values of yaw and pitch angles are shown in Fig. 2. The total pressure from the nozzle inlet is used for non-dimensionalizing. As expected the variation of the pressure with yaw angle is symmetrical. However the pressure is asymmetrical with the pitch due to manufacturing imperfections. Around zero yaw and pitch angles, the pressure is about unity implying that the hole measures total pressure.

The variation of non-dimensional pressures from all holes with  $\beta$  at  $\alpha=90^\circ$  is presented in Fig.3. From the figure it is evident that flow from none of the holes is separated. However the variation of non-dimensional pressures from all holes with  $\alpha$  at  $\beta=90^\circ$  presented in Fig.4 shows that their variation is negligible, indicating that the flow over the probe head at this combination of yaw and pitch angles is separating. Even at  $\beta=80^\circ$  (not shown here), the pressures from all the holes of the probe varies with yaw angle. Hence the probe can be used in the pitch angle range of  $-70^\circ$  to  $85^\circ$ . The limit on the negative side is due to calibration limit. On the positive side, the limit can probably be extended by having holes at different locations.

### Calibration Coefficients Curves

The conventional way to define calibration coefficients for five hole probes is to treat the central hole as total pressure tube, difference between pressures from the left and right holes as a measure of yaw angle and difference between pressures from the top and bottom holes as a measure of pitch angle. The average of the pressures from the four side holes is taken as a measure of static pressures. These pressures are suitably non-dimensionalized with the dynamic pressure measured by the probe (average of all side hole pressures) to obtain different calibration coefficients. However at large angles one or more side holes separate and do not vary with yaw or pitch angle. Hence there is a need for additional holes that need to be drilled on the probe head. The pressures from at least four holes should be in the attached flow region to define different calibration coefficients to obtain the four unknown flow parameters, namely total and static pressures and flow angle in the yaw and pitch angles. Hence the

calibration space (yaw angle:  $\pm 90^\circ$  and pitch angle:  $-70^\circ$  to  $90^\circ$ ) is divided into nine zones in each of which pressure from one of the holes is maximum. This pressure is treated as the centre hole pressure as in the conventional five hole probe and used to determine the total pressure. The zones are shown in Fig.5. At the zone boundaries pressures from two holes are equal. The zone boundaries are not straight lines as shown in the figure but ragged. Further at the zone boundaries there may not any calibration data. Hence the calibration space for all the zones is extended by including calibration data from other calibration zones surrounding the zone under consideration. This is because the probe is calibrated in intervals of  $10^\circ$ , which may not be small enough to precisely define the zones. Also the accuracy of determining pressures and flow angles from the probe measurements is improved. Shepherd [5] had originally used the zonal technique for defining the calibration coefficients of a four hole probe. Later Everett et al. [6] had used this technique for defining the calibration coefficients of a seven hole probe and Sitaram and Govardhan [7] had used this technique to extend the calibration range of five hole probes. Hence no calibration space is left without calibration coefficients. Extended zone for Zone 9 is shown in Fig.5. This zone shares calibration data from eight surrounding zones (Zones 1 to 8). Other zones may share calibration data from smaller number of zones. For Zone 6, additional calibration data from the three surrounding zones, Zones 5, 7 and 9 are used to generate calibration coefficients and curves. The actual zonal locations of the calibration data is shown in Fig.6. Ideally all zones should have nearly equal number of calibration points. However because of manufacturing imperfections, some of the zones have more number of calibration data, while some zones have small number of calibration data. These details are given in Table-1. The percentage difference shown in last row is the difference between the actual percentage of calibration points in the zone and the ideal percentage of calibration points in that zone.

The coefficients in each zone are defined in Table-2. Calibration curve,  $C_{PPITCH}$  Vs.  $C_{PYAW}$  for Zone 9 is shown in Fig.7. The curves are asymmetrical about yaw

**Table-1 : Distribution of Calibration Points in Different Zones**

Zone	1	2	3	4	5	6	7	8	9
No. of Points	50	56	19	38	31	45	25	39	20
Percentage	15.5	17.3	5.9	11.8	9.6	13.9	7.7	12.0	6.2
Percentage Difference	4.4	6.2	-5.2	0.7	-1.5	2.8	-3.4	0.9	-4.9

**Table-2 : Definition of Calibration Coefficients in Different Zones**

	$P_m$	D	$C_{PYAW}$	$C_{PPITCH}$	$C_{PTOTAL}$	$C_{PSTATIC}$
Zone 1	$(P_2+P_8+P_9)/3$	$P_1-P_M$	$(P_9-P_2)/D$	$(P_1-P_9)/D$	$(P_0-P_1)/D$	$(P_S-P_M)/D$
Zone 2	$(P_1+P_3+P_9)/3$	$P_2-P_M$	$[(P_1-P_2)/\sqrt{2-P_3}]/D$	$(P_2-P_1)/D$	$(P_0-P_2)/D$	$(P_S-P_M)/D$
Zone 3	$(P_2+P_4+P_9)/3$	$P_3-P_M$	$(P_9-P_3)/D$	$(P_2-P_4)/D$	$(P_0-P_3)/D$	$(P_S-P_M)/D$
Zone 4	$(P_3+P_5+P_9)/3$	$P_4-P_M$	$(P_3-P_9)/D$	$[(P_3-P_4)/\sqrt{2-P_5}]/D$	$(P_0-P_4)/D$	$(P_S-P_M)/D$
Zone 5	$(P_4+P_6+P_9)/3$	$P_5-P_M$	$(P_4-P_6)/D$	$(P_5-P_9)/D$	$(P_0-P_5)/D$	$(P_S-P_M)/D$
Zone 6	$(P_5+P_7+P_9)/3$	$P_6-P_M$	$[(P_6-P_5)/\sqrt{2-P_7}]/D$	$(P_2-P_4)/D$	$(P_0-P_6)/D$	$(P_S-P_M)/D$
Zone 7	$(P_6+P_8+P_9)/3$	$P_7-P_M$	$(P_9-P_7)/D$	$(P_6-P_8)/D$	$(P_0-P_7)/D$	$(P_S-P_M)/D$
Zone 8	$(P_1+P_7+P_9)/3$	$P_8-P_M$	$[(P_8-P_7)/\sqrt{2-P_9}]/D$	$[(P_8-P_1)/\sqrt{2-P_9}]/D$	$(P_0-P_8)/D$	$(P_S-P_M)/D$
Zone 9	$(P_1+P_3+P_5+P_7)/4$	$P_9-P_M$	$(P_3-P_7)/D$	$(P_1-P_5)/D$	$(P_0-P_9)/D$	$(P_S-P_M)/D$

and pitch angles due to manufacturing imperfections. Calibration curves,  $C_{PSTATIC}$  Vs.  $\alpha$  and  $C_{PTOTAL}$  Vs.  $\alpha$  for Zone 3 and 6 are shown in Figs.8 and 9 respectively. Both of them have reasonable values and gradual variation except near the zonal boundaries.

**Data Reduction Method and Its Validation**

**Data Reduction Method**

A data reduction method available in the laboratory for obtaining flow parameters from measurements taken from a five hole probe is modified suitably for use with the calibration data obtained from the probe to obtain flow parameters from measurements taken from the present probe. The working of the program is given below.

First step in the interpolation method is to identify the zone in which the probe is operating. This is determined by finding the hole (1 to 9) in which the probe measured maximum value. Accordingly the corresponding set of calibration curves are used for the interpolation. The interpolation procedure is briefly outlined below.

The entire calibration data is stored in form of an array in a file which serves as an input file to the program. To calculate the flow parameters for the unknown flow,  $C_{PYAW}$  and  $C_{PPITCH}$  values are calculated using the measured data for the unknown flow. This data is also stored in the input file in the form of an array. Individual curves pass through the  $C_{PYAW}$  versus  $C_{PPITCH}$  calibration curves for each value of  $\alpha$ . At the measured  $C_{PPITCH}$ , the corresponding values of  $C_{PYAW}$  are interpolated from the spline curves yielding the variation of  $\alpha$  Vs.  $C_{PYAW}$ . This result-

ing function, when evaluated at the measured  $C_{PYAW}$  yields the experimental local flow angle in the yaw plane,  $\alpha$ . By interchanging the dependent and independent variables and forming the functional relationship between  $\beta$  and  $C_{PPITCH}$  for the measured value of  $C_{PYAW}$ , the experimental value of the local pitch angle,  $\beta$  can be determined.

Individual spline curves are passed through the  $C_{PSTATIC}$  versus  $\beta$  (or  $\alpha$  depending on the zone) data for each value of  $\alpha$  (or  $\beta$ ). At the interpolated value of  $\beta$  (or  $\alpha$ ), the corresponding values of  $C_{PSTATIC}$  are interpolated from the spline curves yielding the variation of  $C_{PSTATIC}$  Vs.  $\beta$  (or  $\alpha$ ). When the resulting curve is evaluated at the interpolated value of  $\beta$  (or  $\alpha$ ), the experimental value of the static pressure coefficient,  $C_{PSTATIC}$  results. The experimental value of the total pressure coefficient,  $C_{PTOTAL}$  is evaluated in the same manner using the  $C_{PTOTAL}$  Vs.  $\beta$  (or  $\alpha$ ) calibration curves. The total and static pressure at the probe tip can be computed from  $C_{PTOTAL}$  and  $C_{PSTATIC}$ , respectively.

By using Bernoulli's equation, the magnitude of the local velocity is given by

$$C = [ 2 (P_0 - P_S) / \rho ]^{1/2}$$

The velocity components are determined as follows:

$$\begin{aligned} \text{Axial velocity, } C_X &= C \cos \alpha \cos \beta \\ \text{Tangential velocity, } C_U &= C \sin \alpha \cos \beta \\ \text{Radial velocity, } C_R &= C \sin \beta \end{aligned}$$

The interpolation procedure to perform these calculations has been computer adopted.

### Validation of the Data Reduction Method

The interpolation program is run with additional data obtained during calibration. To estimate the accuracy of the probe, the measured data of  $C_{PYAW}$  and  $C_{PPITCH}$  is used to interpolate the values of  $\alpha$ ,  $\beta$ ,  $P_O$  and  $P_S$  and these values are compared with the respective measured values. The difference between the measured values and the interpolated values gives the error which is an estimate of the accuracy of the probe.

The errors for the probe measurements are shown in Table-3. The error in the values of the different parameters is small enough for the probe to be used along with the interpolation. The error in the values of the different parameters is small enough for the probe to be used along with the interpolation program for accurate three dimensional flow measurements. It has to be noted that the errors shown are due to interpolation only. The measurements by the probe also suffer from other errors experienced by five hole probes. A discussion of these errors and their estimated magnitude for measurements with five hole probes are given in Sitaram et al. [8].

### Conclusions

The present paper presents details of design, fabrication, calibration and validation of a nine-hole probe for the measurement of three dimensional flows with large angles. The following major conclusions are drawn.

- The calibration coefficients defined for each zone are found to vary smoothly. Hence the probe can be used to measure three dimensional flows without any major errors.
- The nine hole probe is shown to be useful for the measurement of three dimensional flows with large angles with small errors in total and static pressures and flow velocity and angles.

### Acknowledgements

The authors would like to thank Mr. P. Perumal, who fabricated the probe. The inspiration for the paper has come from the paper of Dr. Ramakrishnan and Prof. Rediniotis [4]. This probe is fabricated for the Project, "Hot Air Calibration of Five Hole Probes", No. 2008/36/106-BRNS/4037 sponsored by Bureau of Nuclear Research Studies, Department of Atomic Energy, Government of India.

**Table-3 : Interpolation Errors in Different Zones**

Zone	Yaw Angle (Deg)			Pitch Angle (Deg)			Total Pressure (mm of Water)			Static Pressure (mm of Water)			Velocity (m/s)		
	$\alpha$	$\alpha_{IN}$	$\Delta\alpha$	$\beta$	$\beta_{IN}$	$\Delta\beta$	$P_O$	$P_{OIN}$	$\Delta P_O$	$P_S$	$P_{SIN}$	$\Delta P_S$	$C$	$C_{IN}$	$\Delta C$
1	15	14.5	0.5	85	84.2	0.8	108.2	106.4	1.8	0	2.0	-2.0	43.1	43.1	-0.04
1	15	14.2	0.8	75	74.3	0.7	108.2	107.4	0.8	0	1.8	-1.8	43.1	43.3	-0.20
1	15	15.2	-0.2	65	65.6	-0.6	106.2	104.4	1.8	0	1.6	-1.6	42.7	42.6	0.04
1	15	15.3	-0.3	55	55.7	-0.7	106.2	105.4	0.8	0	1.4	-1.4	42.7	42.8	-0.12
1	15	14.7	0.3	45	45.7	-0.7	105.8	103.4	2.4	0	1.2	-1.2	42.6	42.3	0.24
1	15	15.4	-0.4	35	35.7	-0.7	105.8	104.4	1.4	0	1.0	-1.0	42.6	42.5	0.08
1	15	14.6	0.4	25	25.3	-0.3	108.2	105.4	2.8	0	0.8	-0.8	43.1	42.7	0.40
9	15	14.7	0.3	15	15.3	-0.3	108.2	105.0	3.2	0	0.6	-0.6	43.1	42.5	0.52
9	15	14.6	0.4	5	5.3	-0.3	107.2	104.4	2.8	0	0.5	-0.5	42.9	42.4	0.46
9	15	14.7	0.3	-5	-5.4	0.4	107.2	105.4	1.8	0	0.4	-0.4	42.9	42.6	0.28
5	15	14.5	0.5	-15	-15.5	0.5	105.2	102.4	2.8	0	0.8	-0.8	42.5	42.1	0.41
5	15	14.3	0.7	-25	-25.5	0.5	105.2	101.9	3.3	0	0.9	-0.9	42.5	42.0	0.49
5	15	14.2	0.8	-35	-35.8	0.8	107.3	103.4	3.9	0	1.1	-1.1	42.9	42.3	0.56
5	15	14.1	0.9	-45	-45.9	0.9	107.3	101.4	5.9	0	1.3	-1.3	42.9	42.0	0.93

**References**

1. Treaster, A. L. and Yocum A. M., "The Calibration and Application of Five-hole Probes", ISA Transactions, Vol.18, No.3, 1979, pp.23-34.
2. Venkateswara Babu, C., Govardhan, M. and Sitaram, N., "A Method of Calibration of a Seven-hole Pressure Probe for Measuring Highly Three-dimensional Flows", Measurement Science and Technology, Vol.9, 1998, pp.468-476.
3. Pisasale, A. J. and Ahmed, N. A., "A Novel Method for Extending the Calibration Range of Five-hole Probe for Highly Three-dimensional Flows", Flow Measurement and Instrumentation, Vol.13, Vol.(1-2), 2002, pp.23-30.
4. Ramakrishnan, V. and Rediniotis, O. K., "Development of a 12-hole Omnidirectional Flow Velocity Measurement Probe", AIAA Journal, Vol.45, No.6, 2007, pp.1430-1432.
5. Shepherd, I. C., "A Four Hole Pressure Probe for Fluid Flow Measurements in Three Dimensions", ASME Journal of Fluids Engineering, Vol.103, No.4, 1981, pp.590-594.
6. Everett, K. N., Gerner, A. A. and Durston, D. A., "Seven-Hole Cone Probes for High Angle Flow Measurement: Theory and Calibration", AIAA Journal, Vol.21, No.7, 1983, pp.992-998.
7. Sitaram, N. and Govardhan, M., "Large Angle Calibration of Five-hole Probes", Journal of the Aeronautical Society of India, Vol.54, No.3, 2002, pp.265-272.
8. Sitaram, N., Lakshminarayana, B. and Ravindranath, A., "Conventional Probes for Relative Flow Measurements in Turbomachinery Rotor Blade Passage", ASME Journal of Engineering for Power, Vol.103, No.2, 1981, pp.406-414.

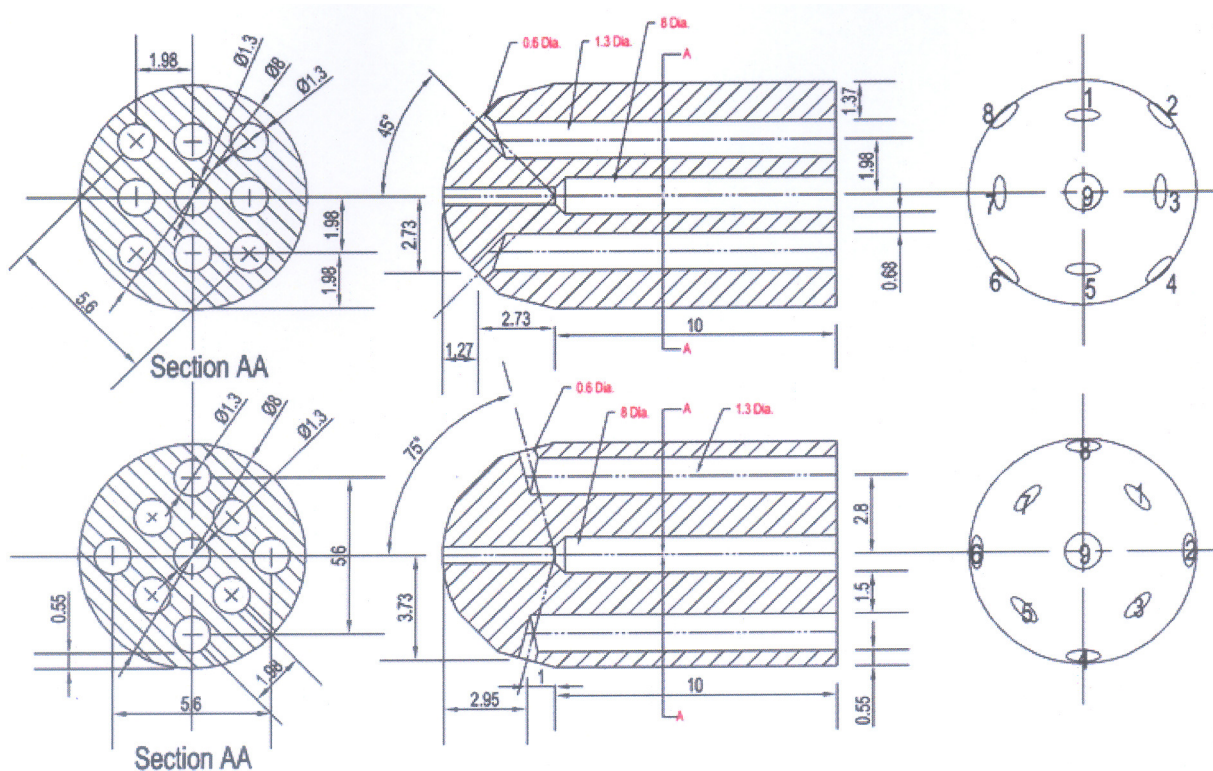

Fig.1 Design Details of Nine Hole Probe

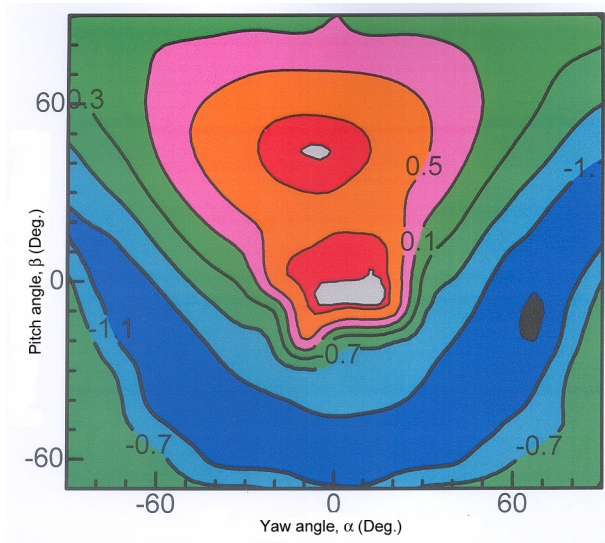

Fig.2 Contours of Center Hole Pressure

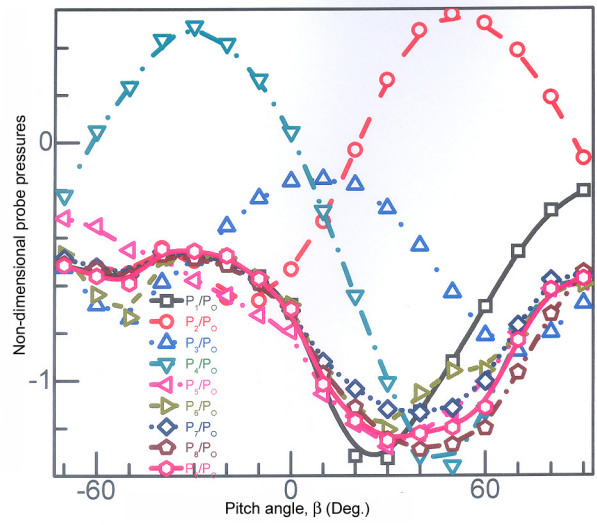

Fig.3 Variation of Pressures Measured by all Holes with  $\beta$  at  $\alpha = 90^\circ$

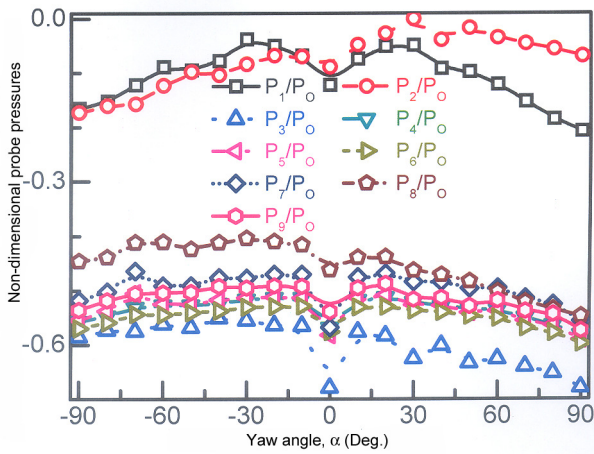

Fig.4 Variation of Pressures Measured by All Holes with  $\alpha$  at  $\beta = 90^\circ$

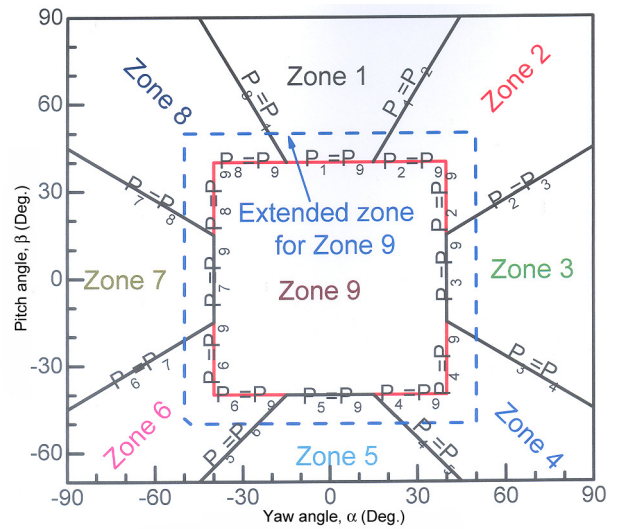

Fig.5 Actual and Extended Zones

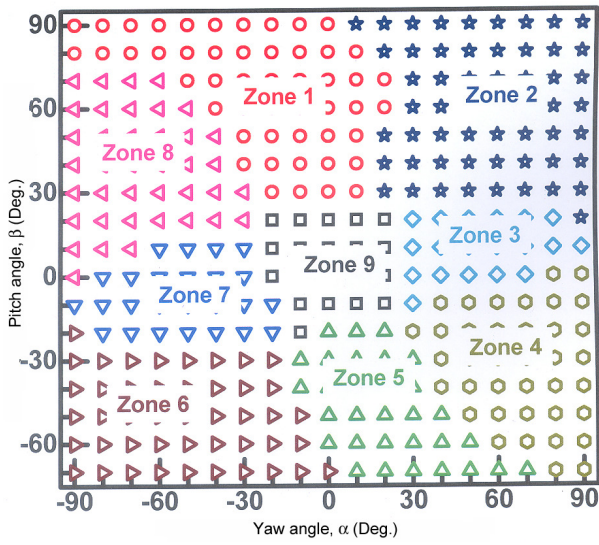

Fig.6 Distribution of Calibration Points in Different Zones

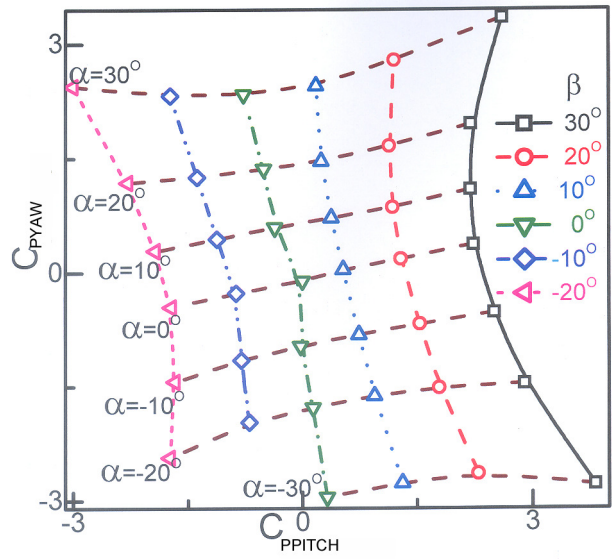

Fig.7 Calibration Curve :  $C_{PPITCH}$  Vs.  $C_{PYAW}$  in Zone 9

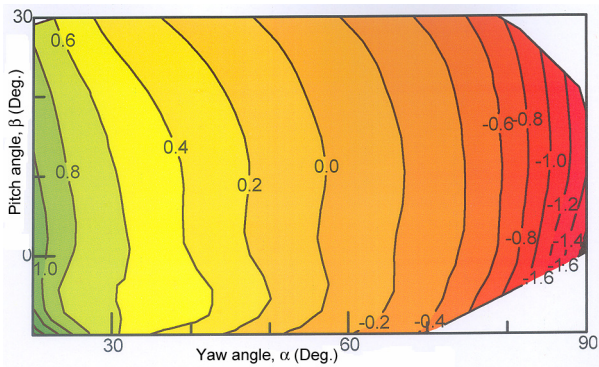

Fig.8 Calibration Curve :  $C_{PSTATIC}$  Contours in Zone 3

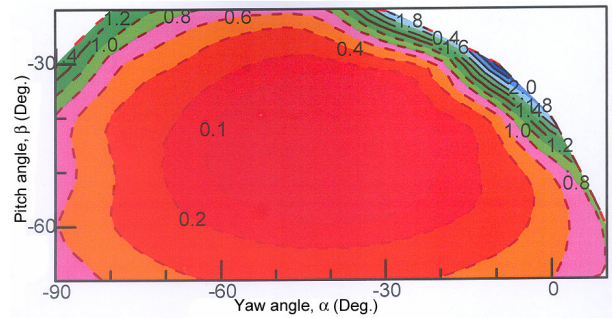

Fig.9 Calibration Curve :  $C_{PTOTAL}$  Contours in Zone 6