

## USE OF POKE-YOKE FOR RIGHT MANUFACTURING AND INSTALLATION

Appasaheb Malagaudanavar; Yogendra Singh and Narender Singh  
 Transport Aircraft Research and Design Centre (TAD)  
 Hindustan Aeroanautics Limited (HAL)  
 Kanpur-208 008, India  
 Email : gmaurdc.nsk@hal-india.com/appanna\_k@rediffmail.com

### Abstract

*Hindustan Aeronautics Limited, Transport Aircraft Division, Kanpur manufactures HAL DO-228 a Light Transport Aircraft. Manufacturing of HAL DO-228 commenced as licensed production with Technology transfer from M/s Dornier GmbH, Germany. All the design data for manufacturing of parts, the manufacturing tooling and the processes were given under the agreement for Transfer of Technology. Number of aircraft have been built over a period spreading to more than two decades starting from the year 1984. In the recent years, we faced two distinct problems. One, defect occurred during manufacturing of two wing spar components. Another, operator faced problem due to wrong fitment of a part. We present these two interesting cases which were resolved by adopting poka-yoke methods.*

### Case I : Manufacture of Symmetric Parts

Most of those who work in aircraft industry are aware of symmetric parts for e.g. Left Hand side (LH) Wing and Right Hand side (RH) Wing, LH Aileron and RH Aileron, LH and RH Flap, LH and RH Elevator assemblies and a few assemblies inside the fuselage. As they are mirror images, in order to save the design man hours, it is a regular practice to have drawing only for LH part. The RH part number is shown as Symmetric and normally will not have a separate drawing. Normally the notations in the drawing reads as "LH as drawn, RH Symmetric".

However, this practice of not having separate drawings can lead to several mistakes like wrong itemisation, wrong fitment and subsequent rework etc.

Because of the symmetric nature, sometimes the drilling templates (fixtures) for big symmetric parts can be single. Both faces of the drill template can be utilised, one side for LH and the other side for RH component. This saves on the tool cost and tool inventory.

Symmetry could also be in the same part about either one axis or two axes. We have two examples of error in production;

- One due to symmetry within the part and

- Another due to symmetrical part

HAL-DO-228 wing has extensive integrally milled components. The 16 meter long wing is of two spar construction. Front spar and Rear spar are built by just three components each. Center spar (Both Front and Rear) is symmetric about the central axis and is about 6 m long. Outer spars LH and RH components (Both front and rear spar) are symmetrical in nature. Outer LH and RH (both front and rear spar) are about 4.744 m long. These parts are milled from plate material first and then pilot holes are drilled using a drilling fixture. During assembly of the wing, the components are positioned in assembly jig and the pilot holes are enlarged to the required size and fastening carried out.

Front Center and Rear Center spars are drilled using separate drilling fixtures. LH and RH outer Front Spar components are drilled using one single fixture but opposite faces of the fixture. Likewise, LH and RH outer Rear spar are similarly drilled using one single fixture but opposite faces of the fixture.

These parts consume about 120 manhours each for milling and final drilling operation. The drilling operation alone consumes about 20 manhours.

After producing about 90 numbers of aircraft, first time a defect was observed during production of rear centre spar. The part was fixed upside down during drilling on the drilling fixture. Hence the drilling pattern required on the upper side of the spar was done on the lower side and vice versa. This operation went unnoticed. During the next assembly, holes on the spar were transferred to the wing skin spar cap. At this time, the defect was noticed.

The defect was referred to the material review board. The Board deliberated on the reasons for the defect and what corrective actions should be taken. It was observed that, the drilling has been done by fixing the part upside down in the drill fixture (Refer Figs. 1a, 1b, and 1c ).

It was a clear case of the Drilling fixture being not able to prevent the loading of part in wrong orientation. Available stops on the fixture could not prevent wrong drilling. The error occurred due to part being symmetrical about its central axis. It was surprising that till such time there has been no mistake i.e. more than 90 parts were produced without mistake. The reasons for the error could be many but one single fact is that the fixture could not prevent wrong drilling. This errors lead to a considerable delay in production. The Board suggested for eliminating recurrence of such thing by either changing the fixture or some other means.

A team of Designers, shop representatives, quality and Tooling sat together and studied the problem with a view to provide solution. A close look at the part and the tool showed that, the tool can be modified to prevent positioning of part in wrong direction. The part has two holes of 52dia one at 470 mm from the centreline towards RH and another at 630mm from the center on the LH side. Exploiting this feature, if the tool has a corresponding mating plug at these locations, part simply cannot be fitted in wrong direction (Refer Fig.1d).

The tool was modified to have raised plugs at these locations. (See Fig.1e). This prevented the possibility of upside down fitting of the part for drilling.

At this point of time we did not look at the drilling fixtures of other spar components. A few years down the lane, a similar defect occurred on front LH spar. While drilling, the front LH spar was positioned on the surface meant for RH front spar on the drilling jig. Once again the defect could be noticed only during wing assembly. In this case the error occurred due to symmetric parts being drilled using one single drilling fixture. This defect was

also studied and once again using the part feature the drilling fixture was modified.

#### **The Lessons Learned,**

- If a part has been produced correctly for long does not guarantee that the mistake cannot happen and the tool is poka-yoke.
- Component features can be exploited to make the tool POKA-YOKE. Look for simple solutions.

This prompted us to check the Drilling fixture of the Front Center spar and rear LH and RH spar also. It was observed that similar to the other two drilling fixtures, these two fixtures also needed poka-yoke corrections. The drilling fixtures were modified once again using the part features. Figs.2a and 2b illustrate the efforts of front centre Spar Poka-Yoke.

#### **Case II : Possible Wrong Installation on Aircraft Leading to Malfunction**

A gill is installed on the top surface of the fuselage using eight screws. ( Refer Fig.3a ) The gill serves as air outlet for cold air unit installed in the air-conditioning equipment bay. The gill is to be installed such that the gill flanges allow air from inside the cold air unit to get sucked by the outside air stream. One of the operators reported a problem of damaged flanges of the gill on one aircraft. He also reported that, the direction of the gill flanges was opposite as compared to other aircraft.

When the operator reported this problem, as the component has been installed on about 90 aircraft and so far no problem was reported it was initially thought that this should be treated as a spurious case. And possibility of damage by maintenance personnel stepping over it was also considered as the most probable cause.

Brushing aside these thoughts, the problem was studied. It emerged that the gill can be installed in opposite direction because of biaxial symmetry of the installation holes (Refer Fig.3b) If anything can be installed wrongly, it will be. Murphy's Law never fails! This can result in air flow onto the gill flanges, the flanges of the gill are not designed to take up this aerodynamic load. This could result in damage of the gill flanges due to excessive air load. The damage to the component will also result in malfunctioning of the cold air unit.

Design change to prevent wrong installation was deliberated and following things were considered :

- New part shall not call for any additional fastener inventory other than already used. (One of the suggestions was to use one fastener of higher size- this would change the inventory).
- It should be possible to rework the existing part.
- The new part shall prevent wrong installation.

An additional fastener was introduced in the center (the same set of fasteners used), This resulted in use of all existing parts and also it ensured that the part cannot be installed wrongly(Refer Fig.3b).

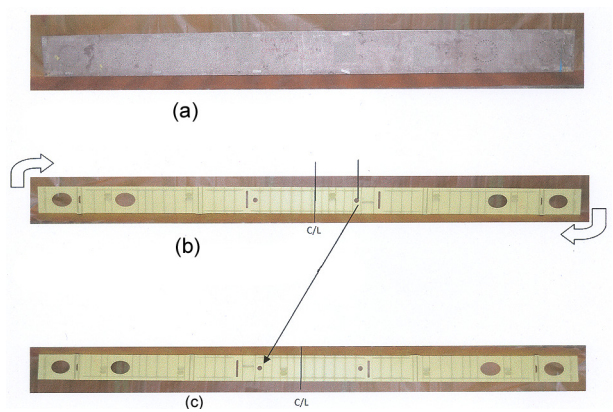

Fig.1a : Drilling Template for Centre Rear Spar;  
 1b : Correct Orientation of Centre Rear Spar  
 1c : Incorrect Orientation of Centre Rear Spar (Upside Down)

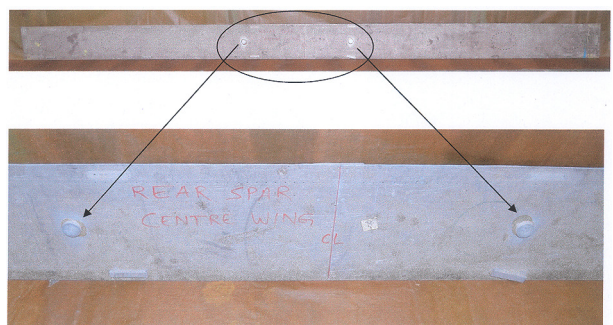

Fig.1e : Mating Plugs at Unsymmetrical Locations w.r.t. Centre Line of Spar

There could be other better ways to do this, for example providing one hole offset. But in the current situation we could not adopt this.

**The Lessons Learned,**

- Do not brush aside the complaints of the operator even if it is one in thousand.
- Look for simple solutions and not complicated ones.
- At the design stage, ensure that the symmetry of the part will not result in wrong installation.

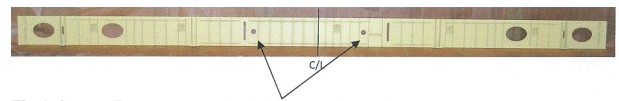
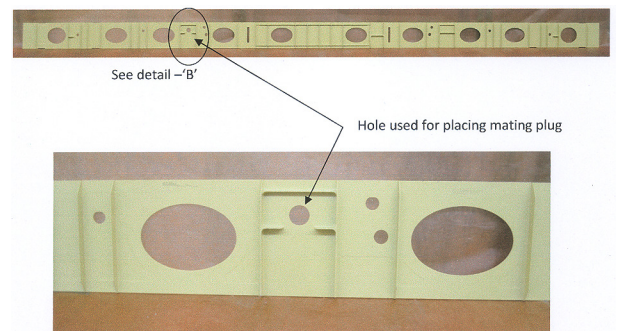

Fig.1d : Two Unsymmetrical Hole Locations Identified for Fitment of Mating Plugs



Detail-'B'

Fig.2a : Front Centre Spar



See detail -'C''  
 Mating plug introduced on drilling template

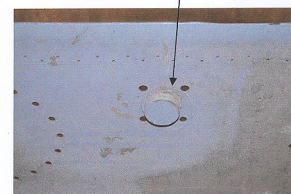

Detail-'C'

Fig.2b : Poke Yoke Action on Front Centre Spar Drilling Template

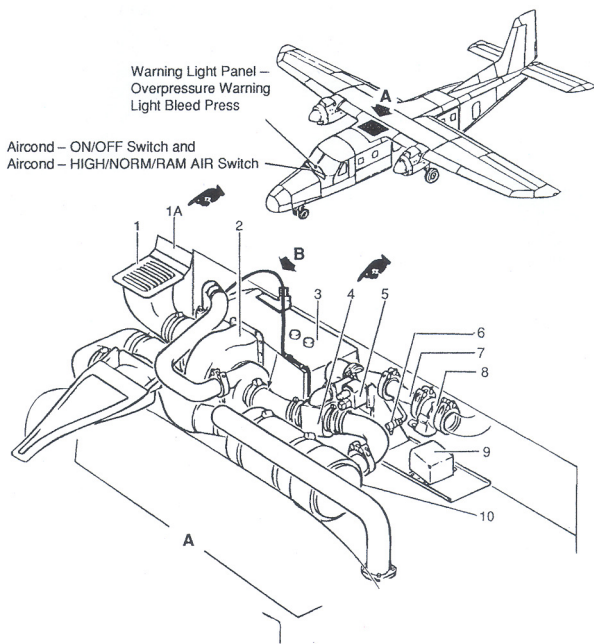

Fig.3a : Installation of Gill Plate

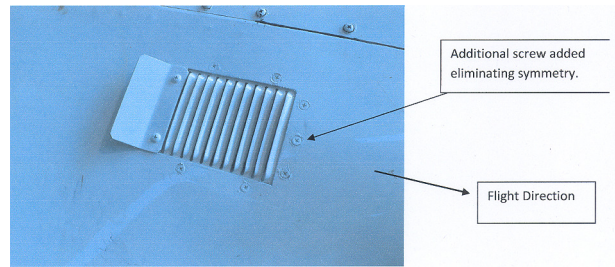

Fig.3b : Installation of Gill Plate : Post Modification