

## OPTIMISATION OF VACUUM BRAZING CONDITIONS FOR JOINING STAINLESS STEEL 321 SHEETS BY NICKEL BASED BRAZE FOIL FOR REGENERATIVE ROCKET NOZZLE APPLICATIONS BY TAGUCHI METHOD

D.P. Sudhakar  
Liquid Propulsion System Centre  
Thiruvananthapuram - 695 547, India  
Email : dpsisro@yahoo.com

V. Vinodh Babu  
Liquid Propulsion System Centre  
Bangalore, India  
Email : vinodhbabu@gmail.com

Abhay K. Jha  
Vikram Sarabhai Space Centre  
Thiruvnanthapuram - 695 022, India  
Email : ak\_jha@vssc.gov.in

M. Rajmohan  
College of Engineering, Anna University  
Chennai - 600 044, India  
Email : rajmohan@anna.univ.edu

A.E. Muthunayagam  
Pro-Chancellor, Noorul Islam University  
Thuckalay, Kaynakumari District, Tamil Nadu, India  
Email : amuthunayagam@gmail.com

### Abstract

*This paper outlines the optimisation of vacuum brazing conditions for joining titanium stabilised Stainless Steel SS321 sheets by Ni-based braze alloy (Ni-Mn-Cr-Co-Si) as brazing filler metal (BFM) for two shelled rocket nozzle applications. This is a specialized brazing technique in which multiple parameters such as temperature, time, argon pressure in the furnace and vacuum level in the channels between the shells are to be precisely controlled in a complex furnace. Brazing temperature, holding time, surface pressure in terms of dead weight and vacuum levels were identified as parameters having significant effect on the bonding strength of a braze joint. Taguchi method was used as a statistical technique for design of experiments to optimise brazing conditions in terms of shear strength.  $L_9(3^4)$  orthogonal array was designed for conducting the experiments with four parameters at three levels ie temperature (1190°C, 1230°C, 1270°C), holding time (10min, 20min, 30min), surface pressure (100kPa, 150kPa, 200kPa) and vacuum level (0.133Pa, 1.33Pa, 13.3Pa). The optimised set of parameters ie temperature: 1230°C, time: 20min, pressure: 100kPa, vac. level: 1.33Pa has been arrived at by Taguchi method via statistical analysis through analysis of means (AVOM) and analysis of variances (ANOVA). Confirmatory test for optimised conditions agreed well with the Taguchi analysis. Also, extensive optical metallography and energy dispersion X-ray analysis across the joint were carried out to study the metallographic morphology across the joint. The fractured surfaces during lap shear tensile testing have also been studied under SEM.*

**Keywords:** Vacuum Brazing, Design of Experiment, Shear Strength, Taguchi Method

### Introduction

Metal joining processes have paved way for engineering excellence in the creative domain of realising complex hardware that withstand hostile service conditions and play a prominent role in modern technologies. Among the

joining methods such as welding, brazing, soldering and diffusion brazing, brazing [1] has certain distinct advantages for specific applications. It offers permanent, strong, ductile, leak proof joints that can take shock and vibration. Several joints can be made in a single cycle and inaccessible joints can easily be brazed. Distortion is minimal and

precise dimensional tolerances can be maintained. It can join dissimilar material with different thicknesses with the ability to preserve metallurgical characteristics. It offers clean joints with good wetting characteristics. Vacuum brazing [2] is effectively used as a joining process for realising many parts for the launch vehicles, satellites, aircrafts and missiles. Parts such as injector assemblies, impellers, heat exchangers etc, employ this process. Realisation of regeneratively cooled two shelled combustion chambers and nozzles of rocket engines need a special type of vacuum brazing technique. Normal brazing calls for control of only brazing temperature and holding time. This technique, however, encounters multiple parameters such as temperature, time, vacuum level in the channels in between the shells, argon pressure in the furnace and rotational speed of the nozzle assembly during brazing. This study covers the optimisation of different brazing parameters at flat coupon level.

Brazing characteristics depend upon temperature, time, joint clearance, surface cleanliness, surface pressure, vacuum level, heating / cooling rates, design and tolerances, etc. The major players among these such as temperature, time, surface pressure, vacuum level have been chosen to be studied for maximising the objective function of lap shear strength. To select appropriate values of these parameters, understand their relative influence on the brazing characteristics (responses), the brazing process and the parameters influencing the response should essentially be studied to ensure optimum performance of the brazed joints. In this study, the brazing conditions for joining titanium stabilised stainless steel SS321 sheets which makes the inner and outer shells of the nozzle with Ni-based braze filler material (BFM) were optimised. The Taguchi method was used for statistical design of experiment (DOE) to optimise brazing conditions in terms of shear strength of the brazed joint [3]. The vital process parameters varied are temperature, time, surface pressure and vacuum level. For each parameter, three levels were chosen based on the literature survey and experience.

The analysis of means (ANOM) and the analysis of variances (ANOVA) were carried about by using the software MINITAB 14 to arrive at the optimised set of parameters. In addition, the joints were subjected to optical metallography and also were examined with a Scanning Electron Microscope (SEM) to see the diffusion characteristics [4,5].

## Design of Experiment and Brazing Procedure

### Base Metals

Titanium stabilised stainless steel SS321 (wt% C = 0.07-0.12, Cr = 17-19, Ni = 9-11, Mn = 2, Ti = 0.8 max, Fe = Bal) procured from M/s Midhani, Hyderabad has been used for the study. Sensitisation (chromium carbide formation) is avoided in this steel by addition of titanium as stabiliser. The mechanical properties are : UTS = 540MPa, YS = 196MPa, El = 40%.

### Braze Filler Metal (BFM)

Nickel based filler alloy in the form of foil with 120 micron thickness has been used as braze filler metal. The chemical composition is : wt% Mn = 34-37, Cr = 17-20, Co = 8-10, Si = 0.8, B = 0.1-0.2, Ni = Bal. The braze alloy has the solidus - liquidus range of 1140-1170°C.

### Parameters and Their Level

In view of minimising the number of experiments, four major parameters were studied at three levels each by Taguchi method to arrive at optimum set of parameters. Taguchi experimental design employs orthogonal arrays with matrix type of experiment [6]. The experimental results are analysed by statistical tables of mean and variance, to arrive at the optimal set of parameters [7]. In our case, we are considering four process parameters namely temperature, time, surface pressure and vacuum level. Three levels of each of them were considered at temperature : 1190°C, 1230°C, 1270°C; time : 10 min, 20min, 30min; pressure : 100kPa, 150kPa, 200kPa and vacuum level : 0.133Pa, 1.33Pa, 13.3Pa.

### Design of Experiment (DOE)

Taguchi methods are statistical methods developed to improve the quality of manufactured goods and more recently applied to other domains such as engineering, biotechnology, marketing etc., Professional statisticians appreciated the improvements brought out by Taguchi's development of designs for studying variation leading to innovations in the design of experiments. The different reasons that cause variation in design parameters and in the manufacturing process are termed as noises. The optimum and most efficient way to solve these problems of variation is to make the design and process insensitive to the effect of noises which are the causes of variation. This underlying principle of Robust design is the back bone of Taguchi analysis.

It is a scientifically disciplined mechanism for evaluating and implementing improvements in a process with parametric optimisation for the objective function, minimising the effects of undesirable noises [8]. It employs orthogonal arrays with matrix type of experiment. A matrix experiment is a set of experiments, where we change the settings of various parameters from one experiments to another. The purpose is to determine the optimum level for each process parameter and to establish their relative significance. After conducting the experiments, the data taken are analysed to determine the effects of various parameters. The analysis of means (ANOM) and analysis of variance (ANOVA) are used to interpret the data [3].

The statistical software MINITAB 14 is used for design of experiment. The experiments were in the form of L9 ( $3^4$ ) orthogonal array as shown in Fig.1. This array has four columns for process parameters and nine rows of the combination of parameters used for conducting the experiments. It has eight degrees of freedom and handles three levels of parameters.

There are nine experiments with parametric variations as given in each row. For example the first experiment will be conducted with all the parameters at level 1. For the second, parameter 1 will be at level 1 and all other parameters at level 2 and so on. Table-1 gives the details of the nine experiments. The range of time and pressure were arrived at keeping the thin sheet nozzle (with back up wall thickness of 0.6mm) application in mind. Taguchi analysis suggests the optimal set of parameters and their relative influence. After arriving at the optimum set of parameters at flat coupon level, bond strength specimens were brazed, tested and validated. These parameters were recom-

mended as favourable set of parameters for the actual hardware.

### Vacuum Brazing Experiments

The nine experiments as given in Table-1 have been carried out with lap shear specimens according to AWS C3.2-63 (specimen size: 127 x 28.5 x 3mm). The overlapping lap length was kept as three times the thickness. The specimen pair as loaded in the vacuum furnace is as given in Fig.2. In order to simulate the pressure loading conditions, a simulated load equivalent to 100kPa, 150kPa and 200kPa was applied on the joint area by molybdenum weights. The nine brazing trials were carried out in a vertical, top loading vacuum furnace. The brazing cycle is as given in Fig.3. Each experiment had three pairs of lap specimens and a metallographic specimen. Some of the brazed specimens are shown in Fig.4.

## Results and Discussions

### Tensile Test

Tensile tests were conducted to determine the shear strength of brazed joint by applying the tensile load at the two ends of the brazed specimens using the Instron 5500R Universal Testing machine. It is evident that although the tensile load was applied to the specimen, shear stress was developed at the brazed joints because of the nature of joint (lap joint). The brazed specimens were drawn at a constant speed of 2 mm/min. The average shear strength of the brazed joints is shown in Fig.5. The nature of the failure and the position of fracture ensured that the strength obtained are the shear strength of the brazed joints. From the results, it was found that the shear strengths for the different trials were the maximum in case of experiment no:6 that corresponds to 143 MPa for the brazing condition of 1230°C, 30min, 100kPa and 1.33Pa vac. Therefore the suggested brazing condition for the maximum shear strength of the brazed joint corresponds to Temperature 1230°C, Time 30min, Pressure 100kPa, vacuum level 1.33Pa among the nine experiments designed. However, this condition may not be the optimum condition. To confirm the optimum condition, it was necessary to carry-out the analysis of means (ANOM) and the analysis of variance (ANOVA) based on the results of these nine experiments which are discussed subsequently.

### Microstructural Analysis

In order to observe the microstructural [4, 5] and elemental distribution across the brazed joints [9], exten-

**Table-1 : DOE by Taguchi Method**

Expt. No.	Temp. °C	Time, min	Pressure, kPa	Vacuum Pa
1	1190	10	100	0.133
2	1190	20	150	1.33
3	1190	30	200	13.3
4	1230	10	150	13.3
5	1230	20	200	0.133
6	1230	30	100	1.33
7	1270	10	200	1.33
8	1270	20	100	13.3
9	1270	30	150	0.133

sive optical microscopy and scanning electron microscopy (SEM) with energy dispersive X-ray (EDX) analysis were carried out in all the brazed joints after conventional metallographic preparation of the brazed samples.

Figure 6(a) shows the optical micrograph of the brazed samples corresponding to experiment 3 of Table-1 while Fig.6(b) shows the SEM micrograph and Fig.6(c) shows the EDS pattern along with the spot elemental analysis at the centre of the brazed joint. It can be clearly seen from Fig.6(a) that while a defectless braze joint has been obtained, it is clearly devoid of any intermetallic phases. Fig.6(b) and 6(c) clearly reveal significant inter-diffusion of ‘Mn’ into the base material and that of Fe into the braze joint indicating that brazing indeed has taken place.

Figure7(a) shows the optical photomicrograph of the brazed sample corresponding to the experiment 6 of Table-1 while Fig.7(b) shows the SEM micrograph and Fig.7(c) shows the EDS pattern along with the spot elemental analysis taken at the centre of the brazed joint. Fig.7(a) shows a clean brazing joint along with the presence of the fine grain at the interface. Presence of fine intermetallics may be observed in Fig.7(a). Careful observation of Fig.7(b) shows clear grain in the braze joint along with the presence of fine intermetallics which is absent in Fig.6(b).

Quantitative analysis of Mn in Fig.7(c) in comparison with Fig.6(c) reveals that more Mn has diffused into base material in the case of brazing at 1230°C in comparison with spectrum brazed at 1190°C. The microstructural observation of Fig.6 and Fig.7 are in complete agreement with the observed mechanical properties [10, 11] of shear tested specimen shown in Fig.5. The SEM micrograph for the optimized set of parameters is given in Fig.8.

**Analysis of Means (ANOM)**

The results of analysis of the means (ANOM) are given in Table-2.

Table-2 : ANOM for Design Parameters				
Parameters	Level			Optimum Level
	1	2	3	
Temperature	114.2	136.9	135.7	T2
Time	125.5	132.7	128.4	t2
Pressure	130.5	128.3	127.9	p1
Vacuum	127.4	134.1	125.2	v2

The values shown in the table are the average values of three shear strength corresponding to the same level of a specific parameter and different levels of other parameters. For example, the first value (114.2) corresponding to the second column and the first row of Table-2 is the average of three values of experiment number 1, 2 and 3 as shown in Table-1. Table-2 shows the optimum level of temperature, time, pressure and vacuum level as T2, t2, p1 and v2 ie 1230°C, 20min, 100kPa and 1.33Pa vac, which are selected based on the maximum value of mean shear strength among three levels of each parameter. It is noted that the optimum condition is different from that suggested based on nine experiments. This optimum condition represents the best condition in terms of shear strength among all possible conditions of the levels of the parameters.

**Analysis of SN Ratio**

Taguchi suggests signal to noise (SN) ratio as the objective function for matrix experiments. Taguchi classifies objective functions into three categories such as the smaller the better type, the larger the better type and the nominal the best type. In our case, the optimum level for a parameter is the level that results in the highest value of SN ratio in the experimental region according to the larger the better type. The larger the better type is used in the present work as it deals with the evaluation of shear strength of brazed joint. According to this type, the SN ratio is calculated using the following equation [3]:

$$\eta = - 10 \log \frac{1}{n} \sum_{i=1}^n \left( \frac{1}{y_i} \right); n = 9 \tag{1}$$

where  $\eta$  = SN ratio,  $n$  = number of experiments,  $y_i$  = value of shear strength of the  $i^{th}$  experiment.

The overall mean value,  $m$ , of the SN ratio is computed by

$$m = \frac{1}{n} \sum_{i=1}^n \eta_i \tag{2}$$

The effect of a level ‘1’ for a parameter  $k$  is given by

$$(m)_k = \frac{1}{N} \sum_{i=1}^N (\eta_i)_k; N = 3; k = T, t, p, v \tag{3}$$

where  $N$  = total number of levels.

The values shown in the Table-3 are the average values of these SN ratios computed by Eq.(1) corresponding to the same level of a specific parameter and different levels of other parameters. The ranks indicate the degree of influence of different parameters on shear strength. Thus, it is seen that temperature (rank 1) has the highest influence and pressure (rank 4) has the lowest influence on the shear strength of the brazed joints. Fig.9 and Fig.10 show the Effects Plots for Means and SN ratios respectively.

**Analysis of Variance**

The analysis of variance (ANOVA) of means [6] is carried out in the present study to quantify the relative influence of the parameters on the response (lap shear strength) by MINITAB 14. The results of the analysis are shown in Table-4, 5 and 6. For each parameter, the ANOVA provides the degree of freedom (DF), the sequential sums of squares (Seq SS), the adjusted (partial) sums of squares (Adj SS), the adjusted means square (Adj MS) and percentage contribution. The percentage contribution of the parameters on the response is computed by using the following equation:

$$\% \text{ Contribution} = \frac{SS_K}{SS_T} \times 100 \tag{4}$$

where  $SS_K$  is the sum of squares due to parameter k and given by

$$SS_K = \sum_{i=1}^N 3 \left[ (m_k)_i - m_1 \right]^2 \tag{5}$$

and  $SS_T$  is the total sum of squares which is given by

$$SS_T = \sum_{i=1}^N (\eta_i - m)^2 \tag{6}$$

It is observed from Table-5 that the percentage contribution of parameters on the response is in conformity with that predicted by the rank of parameters calculated from SN ratios as given in Table-3.

**Confirmation Test**

The optimum level of parameters has been arrived at in Section of Analysis of Means. It is necessary to confirm these by comparing the predicted value of the response with the experimental value. Using the software MINITAB 14, the value of the response corresponding to the optimum level is predicted as 1230°C, 20min, 100kPa and

Level	Temperture	Time	Pressure	Vacuum
1	41.10	41.92	42.23	42.021
2	42.67	42.37	42.15	42.51
3	42.63	42.11	42.05	41.87
Delta	1.57	0.45	0.21	0.64
Rank	1	3	4	2

Level	Temperature	Time	Pressure	Vacuum
1	114.3	125.6	130.5	127.2
2	136.5	132.3	128.6	134.2
3	135.9	128.8	127.5	125.3
Delta	22.2	6.7	3.0	8.9
Rank	1	3	4	2

Source	DF	Seq SS	Adj SS	Adj MS	% Contribution
Temperature	2	962.22	962.215	481.108	82.15877677
Time	2	66.94	66.941	33.470	5.278522604
Pressure	2	14.24	14.241	7.120	1.201627444
Vacuum	2	131.13	131.130	65.565	11.36107318
Residual Error	0	*	*	*	*
Total	8	1117.53			100

**Table-6 : Analysis of Variance for SN Ratios**

Source	DF	Seq SS	Adj SS	Adj MS
Temperature	2	4.79681	4.79681	2.39840
Time	2	0.30818	0.30818	0.15409
Pressure	2	0.07016	0.07016	0.03508
Vacuum	2	0.66331	0.66331	0.33166
Residual Error	0	*	*	*
Total	8	5.83846		

1.33Pa vac. This optimum condition is experimented by additional lap shear trial. The average value of the response (shear strength) determined by test is 149 MPa. It is also noted that this value is higher than those for the nine experiments. Hence, we conclude that the condition T2, t2, p1 and v2 is the optimum one. It is important to note that the shear strength obtained was found to be extremely good.

### Bond Strength Test

This simulates the channel configuration to study the melting pattern, fillet formation and joint strength for the actual configuration of the application. For this, bond strength specimens similar to the NASA standard with simulated channels were brazed and evaluated. The bond strength specimen is as shown in Fig.11. This gives an insight into the braze joint strength and also the fillet formation between the ribs and shell. These specimen were subjected to X-ray which confirmed no blockages and then pressure tested upto 21MPa without any bulging. This indicates that this has more than required margin for actual operating conditions. They were subsequently sectioned to see the fillet formation and found to be good. The specimen before and after brazing are given in Fig. 12a and 12b.

### Conclusions

This study analyses the effectiveness of brazing conditions for joining SS321 steels using Ni based braze alloy in terms of maximising shear strength of the joint by Taguchi method. Four parameters namely temperature, holding time, surface pressure and vacuum level were selected as variable parameters with three levels of each. L9 (3<sup>4</sup>) orthogonal array was used for the design to experiments. The software MINITAB 14 was used to perform ANOM and ANOVA. The following conclusions are arrived at :

- The optimum levels of parameters are T2, t2, p1 and v2 which means temperature: 1230°C, time: 20 min, pressure : 100kPa, vacuum : 1.33 Pa.
- The degree of influence of the parameters on the brazing strength was in the order of T > v > t > p.
- The percentage contribution is highest for temperature (82%) and lowest for pressure (1%). The vacuum (11%) and time (5%) have marginal contribution.
- The optical metallography and SEM analysis of interface and spot elemental analysis reveal clean braze joint and clear grains with fine intermetallics for the optimal set of parameters. The diffusion of Mn from braze alloy into parent metals and Fe from parent into braze alloy were noted.
- The optimum levels of the parameters provided extremely good braze strength for the joining of SS321 by Ni based braze alloy.
- The optimised values were validated in the bond strength specimen which was successfully pressure tested to 21MPa that had more than adequate margin for the nozzle application.

### References

1. Daniel Kay, W., "Ten Reasons to Choose Brazing", Welding Journal, Sep. 2000, pp.33-55.
2. Yoshiaki Arata., Akira Ohmori and Huai Fu Cai., "Studies on Vacuum Brazing (Report II)", Transactions of Journal of Welding Research Institute, Japan, 1983.
3. Yi Qi Wang., Ali Md. Afsar and Jung II Song., "Optimisation of Brazing Conditions for OFHC Cu and ASTM A501 Low Carbon Steel by Taguchi Method", International Journal of Precision Engineering and Manufacturing, Vol.10, No.3, pp.97-104, July 2009.
4. Yue, X., He, P., Feng, J.C., Zhang, J.H. and Zhu, F.Q., "Microstructure and Interfacial Reactions of Vacuum Brazing Titanium Alloy to Stainless Steel Using an AgCuTi Filler Metal", Materials Characterization 59, pp.1721-1727.

5. Ljungberg, L., Warren, R. and Li, C.H., "A Novel method for Identifying Phases Formed in Brazed and Soldered Joints", Journal of Material Science, Letters 9, 1990, pp.1316-1318.
6. Phillip J. Ross., "Taguchi Technique for Quality Engineering", Tata McGraw Hill, Second Edition, 2005, pp.91-179.
7. Wei Li., Jack Hu, S. and Shao-wei Cheng., "Robust Design and Analysis for Manufacturing Processes with Parameters Interdependency", Journal of Manufacturing Systems, 10/21/2, 2002, pp.93-100.
8. Gaitonde, V.N., Karnik, S.R. and Paulo Darvini, J., "Taguchi Multiple - Performance Characteristics Optimization in Drilling of Medium Density Fibreboard (MDF) to Minimize Delamination Using Utility Concept", J. Mater. Process. Techno., Vol.196, No.1-3, pp.51- 53, 2008.
9. Wang Jaun., Li Yajiang., Liu Perg and Geng Haoran., "Microstructure and XRD Analysis in the Interface Zone of Mg/Al Diffusion Bonding", Journal of Material Processing Technology 205, 2008, pp.146-150.
10. Ivanor, A.D., Knestnikor, N.S., Yu V. Blinor., Barysher, M.S. and Ye I. Chulkor., "Microscopic Observation and Mechanical Tests of CuNiCrSi/321 Brazed Joints", Plasma Device and Operations, Vol.6:1, 1998, pp.37-44.
11. Mandal, S. and Ray, A.K., "Correlation Between the Mechanical Properties and Microstructural Behaviour of Al<sub>2</sub>O<sub>3</sub> - (Ag-Cu-Ti) Brazed Joint", Mater. Sci. Engg , Vol. 383, No. 2, 2004, pp.235-244..

Temperature (°C)	Time (Min)	Pressure (kPa)	Var. level (Pa)
Level 1 → 1190	Level 1 → 10	Level 1 → 100	Level 1 → 0.133
Level 2 → 1230	Level 2 → 20	Level 2 → 150	Level 2 → 1.33
Level 3 → 1270	Level 3 → 30	Level 3 → 200	Level 3 → 13.3

Experiment No	Column No			
	1	2	3	4
1	1	1	1	1
2	1	2	2	2
3	1	3	3	3
4	2	1	2	3
5	2	2	3	1
6	2	3	1	2
7	3	1	3	2
8	3	2	1	3
9	3	3	2	1

Fig.1 Assignment of Levels of Parameters

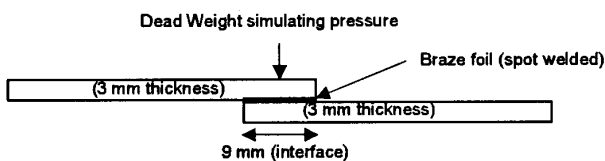

Fig.2 Lap Shear Specimen Pair

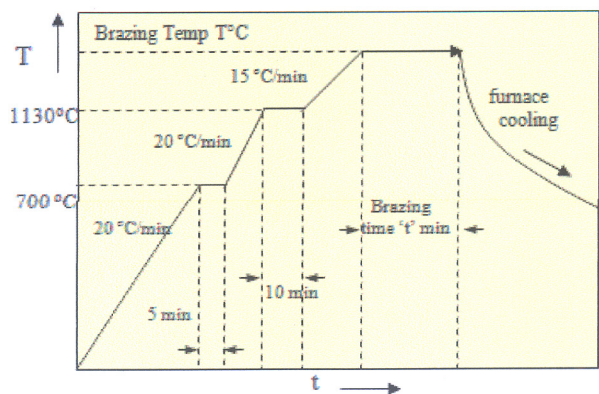

Fig.3 Brazing Cycle

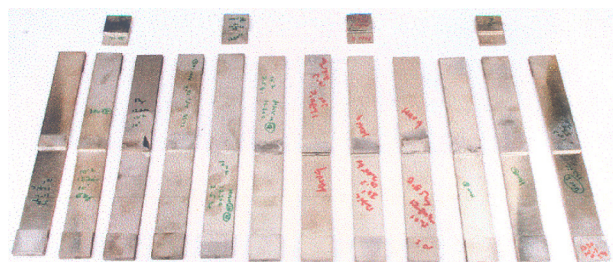

Fig.4 Some Brazed Lap Shear and Metallographic Specimens



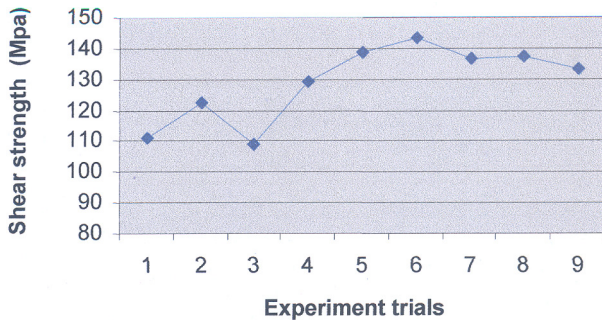

Fig.5 Average Shear Strength of Brazed Joints

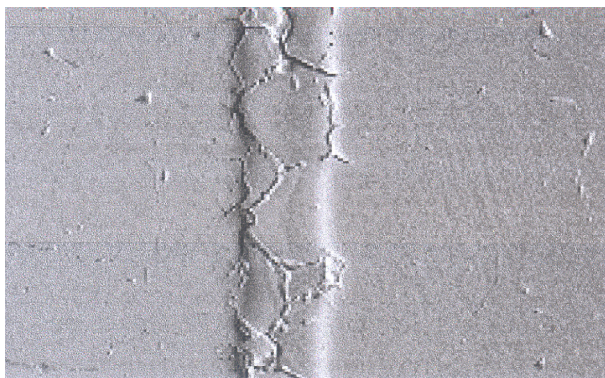

Fig.8 SEM Micrograph for Optimized Set of Parameters

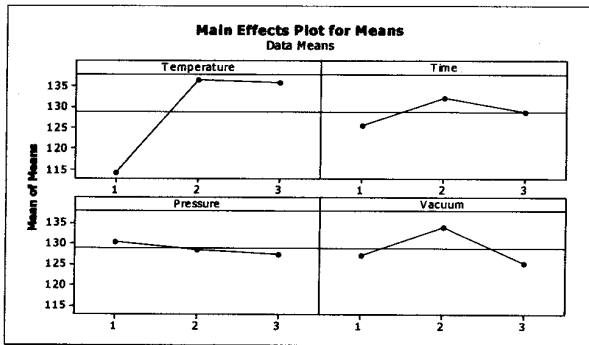

Fig.9 Effects Plot for Means

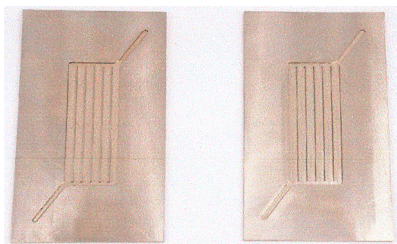

Fig.12a Bond Strength Specimen Before Brazing

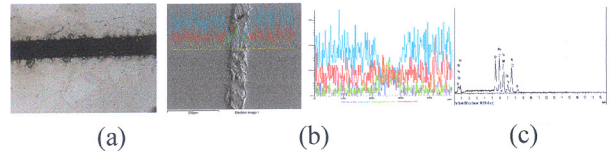

Fig.6 (a) Optical Micrograph of the Experiment Three Brazed Samples, (b) SEM Micrograph of the Experiment Three Brazed Samples, (c) EDS Pattern of the Experiment Three Brazed Samples

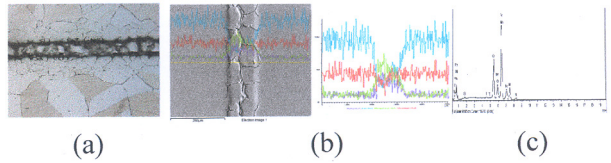

Fig.7 (a) Optical Micrograph of the Experiment Six Brazed Sample, (b) SEM Micrograph of the Experiment Six Brazed Sample, (c) EDS Pattern of the Experiment Six Brazed Sample

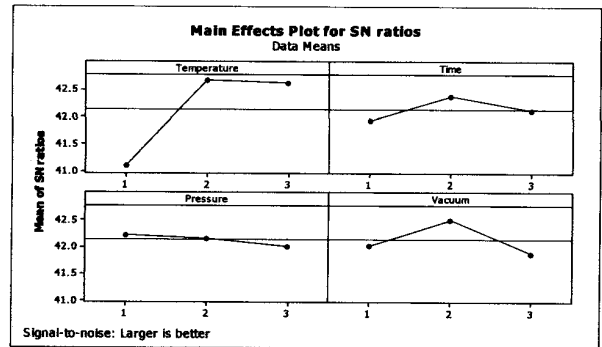

Fig.10 Effects Plot for SN Ratio

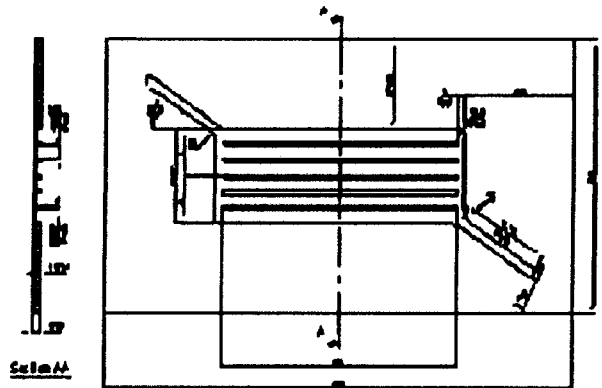

Fig.11 Bond Strength Specimen Drawing (SS - SS)



Fig.12b Bond Strength Specimen Brazed, Pressure Tested and Sectioned