

The three Antenna Arrays arranged in a triangular configuration and placed inside the circular Radome provide 120° of radar coverage each, adding up to 360° in total.

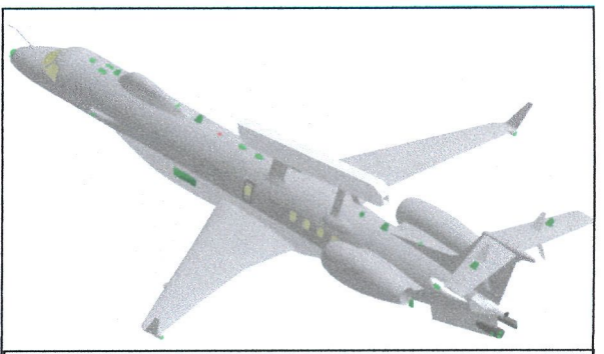

INDIAN EMB-145 AEW&C SYSTEM

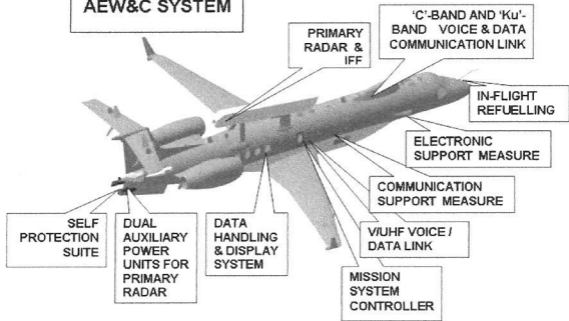

AAAU



'Side-looking' AESA Radar

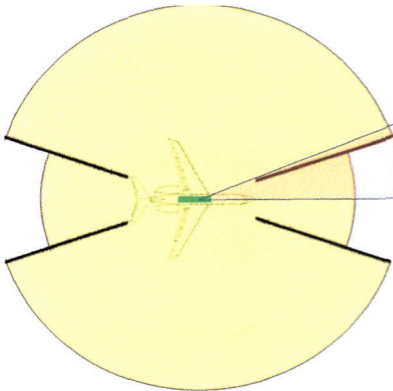

'Side-looking' Radar Arrays on LH and RH sides provide 120°-150° Radar Coverage at 100% range on both the sides.

Additional Antennae in the nose and tail of aircraft can fill up the gaps of 30°- 60° in Radar Coverage with about 70% Range in the fwd and aft directions .

US E-3

awacs



ACTIVE ESA

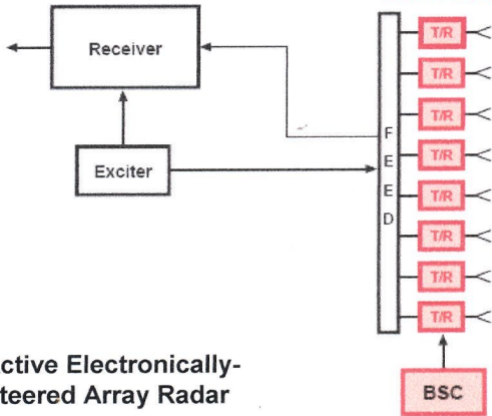

Active Electronically-Steered Array Radar



Phased Array Radar

T/R MODULE

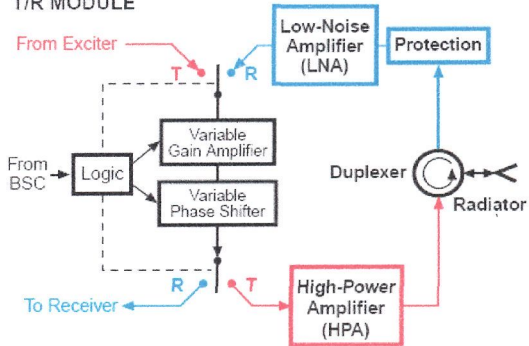

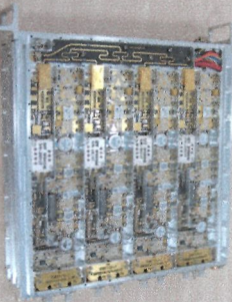

TRMM





