

SOME PRACTICAL HINTS ON PRESERVATION OF AIRCRAFT ENGINES USING A RIG FROM CORROSION PROBLEMS

Gurumurthy Vijayan Iyer*

Abstract

*Aircrafts need to be grounded for want of routine scheduled maintenance and inspection after certain period of flying hours. During such maintenance practices, the turbo-propeller engines are kept dismantled, un- installed and non-operative conditions for a longer period even up to two years. During this non-operative period, the engines and components are susceptible to extensive chronic corrosion hazards. To prevent this hazard, the engines and components are required to be preserved both internally and externally from corrosion that is the engine components such as turbine, turbine blades, compressor, fuel nozzles, fuel system pipelines, diffuser, combustion cum mixing chamber, expansion nozzle and exhaust manifold. **Over the long experience of operating the aircrafts, it has been observed that the appliance provided by the manufacturer is only meant for internal corrosion preservation purposes of the operative and installed engines and cannot be used for external corrosion preservation of non-operative and un installed engines which led to drastic reduction of engine lives and unsafe operating conditions to the aircrafts due to inherent materialistic corrosive effects.** The material of the turbine blades could not able to withstand its designed high combustion temperature due to the corrosion problems, which leads to unsafe engine conditions. The problem was attributable to the design factor that the high pressure cock in the fuel supply system could open and allow the preservative oil to enter into the main fuel system only when sufficient oil pressure is built up in associative oil system, which needs rotating the engines at least in idling speeds. Simulating this mandatory condition is not possible for the non-operative uninstalled engines.*

*To overcome the corrosion hazard problem of aircraft engines, a bogie hinge joint flushing device has been designed, fabricated and tested using the local resources after taking into consideration of this important engine external preservation requirements, layout of the turbo-propeller engine power plant and fuel supply systems. **This innovative external preservation rig has got multiple options coupled with internal preservation for preserving the engine components such as turbine, turbine blades, compressor, fuel nozzles, fuel system pipelines, diffuser, combustion cum mixing chamber, expansion nozzle and exhaust manifold during the course of long maintenance period.** The newly designed and developed external preservation rig has resulted in achieving the complete external preservation requirements of following categories of turbo-propeller engines. a) New/overhauled engines in storage and kept on expiry of preservation life b) Installed engine required to be removed for storage but cannot be cranked or rotated c) Installed engines that are not in running condition/installation-seized engines d) Uninstalled engine for defect investigations/defect rectifications e) Non operative unsafe engines*

Introduction

After certain hours of flying, aircraft needs to be grounded for want of routine scheduled maintenance in-

spections. During these inspections, the engines are kept non-operative for a longer period. During this non-operative period, the engines are susceptible to extensive

* Consultant, 23/30, Mariaman Koil Street, Phase-V, Parkhavi Apartments, KK Nagar (W), Chennai-600 078, India
Email : gvijayan33@hotmail.com

Manuscript received on 19 Nov 2004; Paper reviewed and accepted on 07 Jan 2005

chronic corrosion. The aircrafts are operated, maintained and parked in the moisture and marine environment of the coastal line full of salt deposits, which greatly aggravate the corrosive properties of material of engine components. The material of the aircraft, engine and associated equipments are subjected to heavy corrosion, various temperatures and weather conditions. The materials of the turbo-propeller engine components need to withstand high combustion temperature to which these are subjected (Fig.1). The engines, which are in use, are less susceptible to corrosion effects due to the regular circulation of internal fuels and lubricants including internal preservation procedures as laid down by the manufacturer (Fig.2). This internal preservation rig provided by the manufacturer can be used only for internal preservation of engines that is the pipelines are filled with recommended lubricating oil at a suitable temperature. Then, the oil is circulated in all parts of the engine [2,3]. This preservation system is an on-line maintenance system exclusively meant for the operative installed engines and cannot be used for non-operative uninstalled engines, which led to the drastic reduction of engine lives and unsafe engine conditions. The corrosive properties of engine materials with respect to temperature are not maintained considerably due to this lack of external engine preservation requirements in respect of non-operative uninstalled engines. To prevent against this corrosive hazard, the engines are required to be completely preserved both internally and externally. To carry out this maintenance practice, there is a need of engine preservation rig for operative and non-operative engines, which

can be used to preserve the engines from corrosion externally and internally. During the servicing of aircraft, the components are dismantled from the aircraft, troubles are suited, checked by engine test beds and other suitable facility of respective system [1]. The inspections are carried out as per the laid down procedures by the manufacturer using technical descriptions and maintenance manual. After servicing, the systems are assembled back in the respective aircraft and checked for its serviceability "S". At last, after the satisfactory functioning of engine, the aircraft has to be cleared for flying by signing in the aircraft logbook. Over the long experience of operating the aircrafts, it has been observed that there is a necessity for an engine preservation system which will facilitate the testing of an aircraft engine using an external preservation rig for totally safest aircraft system which has zero material defect, zero breakdown and free from corrosion hazards while complying the safest material requirements [1,2].

Materials and Methods

The aircraft engines are the aerial altitude turbo propeller power plant operating jointly with a variable pitch propeller of left hand rotation [4]. Fig.1 depicts engineering layout of turbo-propeller aircraft showing internal and external preservation requirements. The turbo-propeller aircraft unit consists of the main units namely, a planetary reduction gear, a front casing, a ten stage axial flow compressor, an annular combustion chamber, a three stage

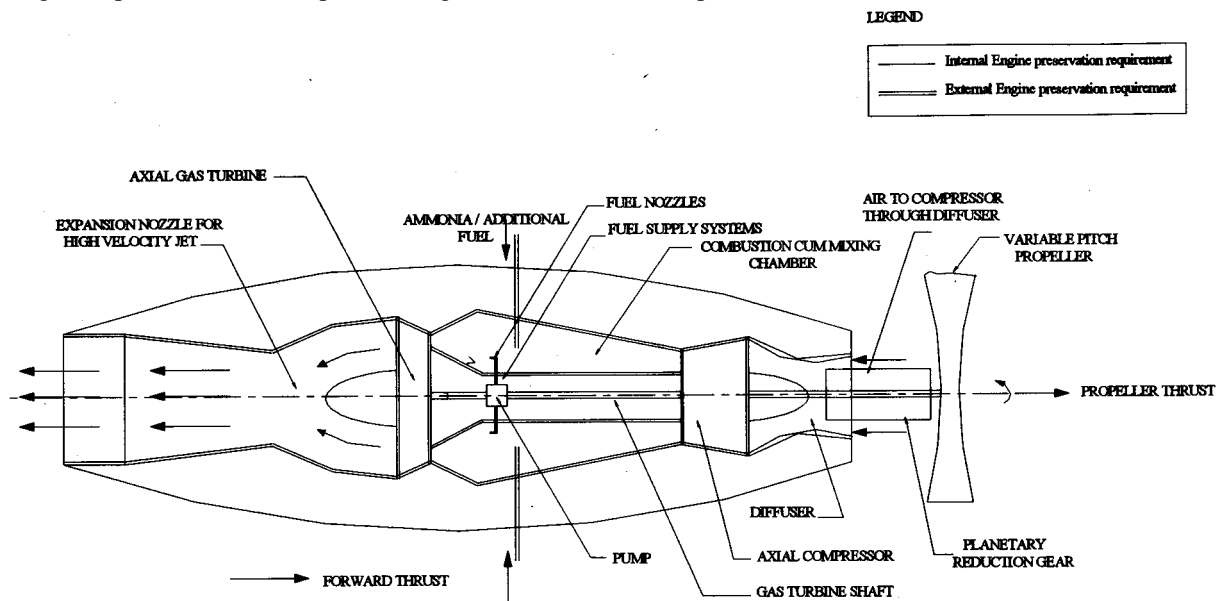

Fig.1 General engineering layout of turbo propeller aircraft showing internal and external corrosion preservation requirements

axial turbine, a fixed area jet nozzle for high velocity jet as well as aircraft accessories.

The air enters the aircraft turbo propeller unit at a velocity equal to that of the aircraft through a diffuser whereby the pressure of air rises to above atmospheric. A ten-stage rotary compressor axial flow type further compresses the intake air to a pressure of 6 bar and supplied to the annular combustion chamber. The liquid fuel under the pressure is injected and sprayed into the combustion chamber by means of a pump through a ring of fuel nozzles. The fuel is burnt at constant pressure in the combustion cum mixing chamber. The products of combustion are then expanded in multi stage axial flow turbine where they lose some of their pressure thus imparting momentum to the turbine rotor and rotary motion to the turbine shaft. The products of combustion after expansion through the turbine are discharged through the nozzle. The high velocity jet emerging out from the nozzle provides turbojet forward thrust energy to the aircraft. The turbine gives power to drive the axial flow compressor and variable pitch propeller. The speed of the propeller can be maintained and varied as per the requirements by a planetary reduction gear before the power is finally transmitted to the propeller [4]. The work involved in this project has been classified in to following groups :

- Studying about the requirement of innovative engine external preservation rig. The requirements of rig and the advantage of using the external presentation rig are presented.
- The existing internal preservation rig for the engine is given in Fig.2. The limitations with this rig have been

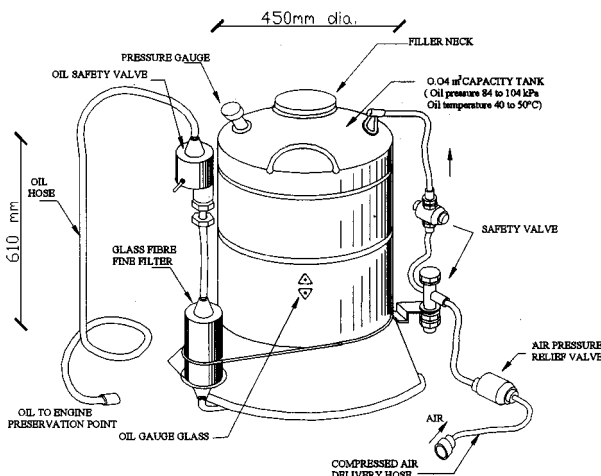

Fig.2 Existing engine internal preservation rig

studied. Considering the limitations, a new design of engine external preservation have been designed.

- Technical requirements of the external preservation rig: Technical requirements for the external engine preservation have been carefully studied. The corrosion problems were identified, prepared, analyzed and evaluated in respect of engine external preservation requirements. Accordingly, an engine external preservation rig has been successfully designed, fabricated and evaluated. The Fig.3 shows the bogie hinge joint flushing device, which is an innovative device or rig designed and developed for engine external preservation.
- External preservation testing procedure of fuel manifold, combustion chamber, turbine blades are given in Fig.4.
- External preservation testing procedure of starting fuel manifold is provided in Fig.5.
- External preservation testing procedure of compressor gas flow path is given in Fig.6.
- Studying the requirements of suitable material and spare parts for manufacturing the rig [4].
- Method of Assembling: The joints are welded and tested by non-destructive method.
- Carrying out functional check on ground: The test rig has been successfully tested and snags were rectified.

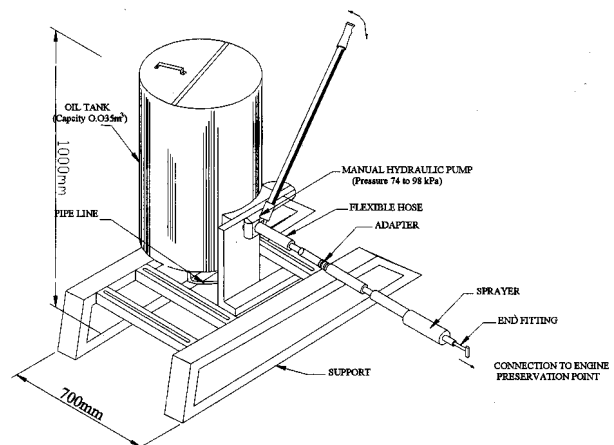

Fig.3 Newly designed bogie hinge joint flushing device for engine external preservation requirements

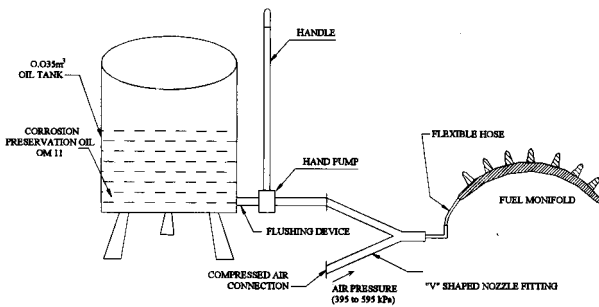

Fig.4 External preservation testing procedure of fuel manifold, combustion chamber and turbine blades

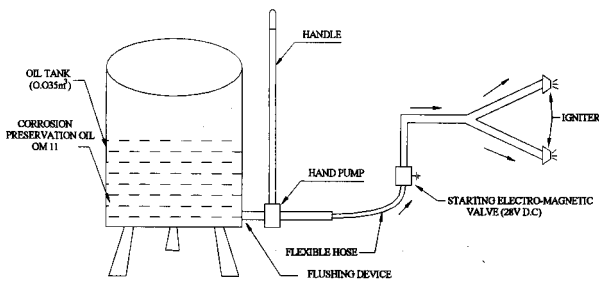

Fig.5 External preservation testing procedure of starting fuel manifold

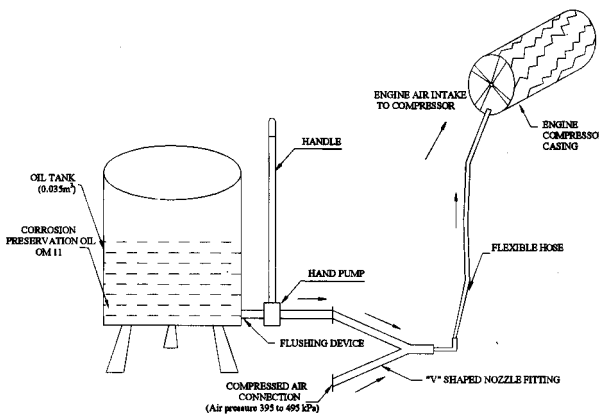

Fig.6 External preservation testing procedure of axial compressor air flow path

- Carrying out trials on the non-operative uninstalled aircraft and identifying all the defects. Further necessary investigations, rectifications and modifications on existing system, equipment and indigenous activities will be preformed.

Trouble Shooting

An aircraft engineer/ technician need to investigate thoroughly the maintenance, operation, repair and overhauling of the aircraft by identifying the problems, preparing the necessary trouble shooting statements, predicting, analyzing and evaluating the problems thereof using pro-

cedures and systems and need to solve the problems by incorporating the mitigation measures.

Importance of Overhauling, Inspection and Repairs (Repair Cycle)

Mechanical failures, improper handling, improper operating conditions will result to disastrous situations. Hence, proper operations, repairs, overhauling and inspections have to be carried as per the maintenance schedules.

Inspection

All parts open and closed are inspected for wear and tear. Worn out / unworkable components are removed. Necessary settings, adjustments to be done. Proper lubrication is to be provided. Various fasteners to be tightened, All parts are to be inspected for wear and tear. All safe guards are to be checked.

Repairs

All repairable parts of the system after inspection are corrected for small repairs and minor defects are rectified. Systems like open systems may be repaired. All aircraft engine components are to be adjusted and repaired as per the conditions.

Overhauling

Dismantling the assembly and replacing the systems such as damaged components may be replaced and various sub mechanisms are to be aligned / adjusted. All the systems are completely dismantled. Components, worn-out and beyond repairs are replaced. Structures and safety guards may be repaired as the conditions. Cleaning, inspection, tightening up and readjustment minor replacements. Adjustments and checking for proper functioning and efficiency. Planned and scheduled reconditioning and reassembly including replacements are preformed.

Process-I: Inspection and checking of parts of aircraft.

Process-II: There adjustments repairs, and replacement.

Repair cycle

Typical Repair cycles for an aircraft system need to be followed as per the repair cycle mode. Repair cycles

involves 15 inspections (I), 4 repairs (R), 1 overhauling (O) which are given below:

The repairs cycle follows:

I-1, I-2, I-3, (1 to 6 months), I-4, I-5, I-6, I-6, R-2, I-7, I-8, I-9, R-3, I-10, I-11, I-12, R-4, I-13, I-14, I-15, O-1

"I" denotes Inspection, "R" denotes Repairs, "O" denotes overhauling

Types of Maintenance

An aircraft is maintained on the basis of the following maintenance practices:

Breakdown Maintenance : Maintenance that can be done after break occurs. This type of maintenance is performed due to unpredictable failures of system components, which cannot be prevented. This is done due to gradual wear and tear of the parts and breakdown takes place. The defects are rectified when components cannot perform its function and longer performance. This maintenance practices are very expensive due to idleness of aircrafts.

Preventive Maintenance : The aircraft systems are maintained on the basis of prediction or periodic checking. This ensures the following checks.

- Reduction in maintenance cost,
- To locate the sources of troubles and solve the problems before breakdown,
- Inspection, lubrication, checking up finding the breakdown costs, idle time of machine is less and avoiding breakdowns,
- Maintaining the quality and ensures proper conditions,
- Ensures minimum wear and tear,
- Ensures safety and minimized the accidents and disasters,
- Ensures maximum efficiency

Scheduled Maintenance : Inspection and lubrication activities are performed at predetermined schedules. This type of maintenance is also called as planned and scheduled maintenances.

Predictive Maintenance : It makes the use of human senses. The instruments used are namely audio gauges, vibration analyzer, noise monitoring meters, strain gauges, checking for hand touches and for unusual sounds.

Characteristics of Aircraft Engine :

Leading particulars

Engine type	-	Turboprop
Propeller and engine rotor sense of rotation (if looking from jet nozzle)	-	Left Hand
Reduction gear type	-	Planetary with torque - meter and negative thrust automatic feathering transmitter
Compressor type	-	Axial flow
Number of stages	-	10
Pressure rise ratio at normal rating (H = 8000 m V = 175 m/sec)V	-	9.2
Compressor air blow off valves		
Number	-	4 pcs, hydraulically controlled

Results and Discussions

Effect of engine performance parameters with respect to corrosion effects.

- As per the engine heat balance sheet, there is 20-24% identified heat loss took place which reduces the performance of the engine.
- Engine does not run at economical speed conditions with respect to minimum brake specific fuel consumption, minimum frictional power and maximum availability of brake power.
- Performance deterioration due to the non-compliance of optimum heat transfer requirements to power at brakes, cooling and exhaust systems.
- Drastic reduction in combustion efficiency 10-15% because of incomplete combustion.

- The air-fuel ratio and temperature in the gas turbine is maintained as 60:1 and 1250 deg C respectively. The net turbo propulsion thrust is equal to the sum of turbojet thrust plus propulsion thrust. During the longer maintenance period, corrosion takes place over the engine and associated pipelines. The corrosion hazards over the materials cause the reduction in engine lives with the resultant unsafe conditions. The metallurgical properties will vary in respect of corrosive materials with deficiency in resistant to the designed combustible temperature. Hence, engine deterioration takes place in improper maintenance of the air fuel ratio and temperature and thus causing engine seizure with the resultant curtails of output power and thermal efficiency. Due to the corrosion hazards, the net turbo propulsion thrust has been reduced considerably to 20%.

General Construction, Basic Specifications, Operating Procedures and Drawbacks on Existing Internal Preservation Rig

General Construction : The appliance is essentially a welded tank. Arranged in the upper part of the tank are a pressure gauge, tank, filler neck, filter, compressed air delivery pipe connection and safety valve. A pipeline is connected to the air delivery pipe connection. Two reducers are built into the pipeline to reduce the pressure of the compressed air delivered to the tank from the ground compressed air source down to 149 kPa. There are two oil gauge glasses in the middle part of the tank to measure the oil level. Mounted at the bottom of the tank is an outlet pipe connection, which is connected to a pipeline with a built-in fine filter and valve delivering oil into the engine. Connected to the valve is a hose, which terminates in a pipe connection to be coupled to the engine. The tank is provided with two carrying handles. To ensure stability of the tank, the latter is placed on a cone-shaped support. Fig.2 depicts existing engine internal preservation [1].

Basic Specification : a) Working pressure = 118 to 149 kPa. b) Tank capacity = 0.04 m³. c) Overall dimensions : height = 610 mm and base diameter = 450 mm

Operating Procedure of Internal Preservation Rig : When preparing the appliance, proceed as follows:

- Warm the preserving oil between the range of 40 to 50 deg C at an ambient air temperature
- Connect the hose to the ground compressed air bottle
- Open the valves on the bottle and on the preservation rig oil tank and relieve the pressure from the hose, and then close the valve
- Adjust the pressure in the tank in the range of 84 to 104 kPa by means of an air relief valve
- Connect the hose filled with oil to the aircraft fuel system pipe connection and open the valve
- Carry out preservation of the fuel system in compliance with the engine operating instructions.
- After the engine shut-down close the transformer oil delivery valve
- Disconnect the compressed air bottle and bleed the air from the rig tank
- Disconnect the transformer oil delivery hose and stop up the pipe connection.

If the level of remaining oil is below the 0.007m³ mark, replenish the preservation appliance tank with oil. Fill the tank with oil only through filters. After completing the engine internal preservation, drain the remaining oil from the tank. Each time before preservation, wash the tank with de-hydrated kerosene and fill it with fresh oil. Prior to placing the rig in storage, blank the ends of hoses [2].

Drawbacks of Internal Preservation Rig

- Internal preservation rig is not effective for complete corrosion preservation due to on-line maintenance practices and does not fulfill the preservation requirements.
- Operators require special training on operation of this rig.
- The rig is difficult to maintain operational aspects due to non-availability of spares.
- Prone to brushing due to requirement of pressurization.
- It does not effect 100% preservation of the engines.

Construction, Basic Specifications, Modified Operating Procedures and Advantages of New Rig

Construction: The rig comprises of a oil tank of 0.035m³ capacity instead of 0.040 m³ as of original rig tank capacity was considered sufficient which is mounted on a base

support and is welded with structure of cast iron angles. The tank has one in number delivery point from which oil is delivered through metal rigid pipeline to hand pump. The hand pump designed to build up pressure in the range of 74 to 99 kPa was obtained/retrieved from old unserviceable aircraft lifting jack. The overflow line from the hand pump is connected back in the suction/inlet line. The output of the hand pump is conveyed through flexible hose and various sprayers and adapters manufactured locally as per requirement to the engine points of preservation. Fig.3 shows the newly designed bogie hinge joint flushing device for external preservation requirements.

Basic Specifications : a) Capacity of oil tank = 0.035m^3 .
b) Hand pump output pressure range = 74 to 99 kPa.
c) Dimensions : Height = 750 mm, Length = 1000 mm, Width = 500 mm.

Due to above modification/manufactured engine preservation rig, the operating procedure (from one point to other point) also happened to change in small steps in the previous procedures which is followed by us as per technical operating instructions manual and maintenance manual. The new procedures are given below:

Operating procedures for preservation from engine preservation point to fuel Inlet are as follows

- Remove and wash the engine fuel fine, coarse filters and fuel filter
- Open the blanking cover from the combustion chamber drain.
- Connect the outlet pipeline connection of preservation rig through which the corrosion preservative oil (OM 11) is delivered to engine fuel system, to aircraft preservation point.
- Disconnect the fuel inlet connection to fuel control unit of aircraft engine.
- Start pumping the hand pipe on the preservation trolley to allow preservation oil into the fuel system.
- During the process of supplying oil into the system crank the engine if possible by rotating the propeller, to augment the flow of oil.
- Pump in 0.01 to 0.015 m^3 of oil (OM 11) into the system and ensure flow of preservation oil (hot) from the outlet of engine high-pressure pump.

- Disconnect the preservative oil line connection and blank engine preservative point.

Operating procedures for preservation of fuel control unit of the engine are given below:

- Connect outlet connection of engine internal preservation device to fuel inlet of filter.
- Disconnect the filter and fuel outlet pressure transmitter connection.
- Pump in the preservative oil into filter and watch for the flow of hot preservative oil from the preserve transmitter outlet.
- Disconnect all the external connections and give connection of disturbed pipelines and wire lock it.

Operating procedures for preservation of fuel manifold, combustion chamber, turbine blade, 20% Fuel by pass line and starting manifold with igniters as appended below:

Figure 4 depicts the external preservation procedures for fuel manifold, combustion chamber, turbine and fuel systems. Fig.5 depicts external preservation procedures for starting manifold

- With the help of 'V' shaped three way union, connect one end of three way union to the outlet pipe line connection of flushing device through which the preservative oil (OM-11) is delivered to fuel manifold, and the other end to air trolley. Connect the outlet of three union to inlet of fuel manifold (Fig.4).
- Pump in preservative oil (OM 11) and at same time supply 399 to 495 kPa of compressed air at the other end of union.
- During the process of supplying oil into the system, crank the engine with the help of a propeller. Do not crank, if the engine is seized.
- Watch for the oil vapour at engine exhaust and ensure the presence of oil coating on the last stage of turbine by visual check.
- Disconnect 'V' shaped three way union connection from fuel manifold inlet and pump in preservative oil OM 11 into fuel manifold inlet with help of flushing rig for 1 to 2 minutes and at same time give 28 V DC external supply to 20% fuel by pass electromagnetic valve for preserving the fuel by pass line (Fig.5).

- Confirm sufficient amount of oil drained from the combustion chamber drain point.
- For preserving starting fuel manifold and igniters, connect the preservative oil collection from the flushing rig to inlet of starting fuel manifold. Pump in preservative oil for 2 to 3 minutes and the same time open the electromagnetic valve with help of 28 V DC external power supply (Fig.5).

Operating procedures for external preservation of engine compressor

- Prepare new engine internal preservation device. Clean and flush the tank and pipes lines with the help of preservative oil (OM-11).
- With the help of 'V' shaped three way union, collect one end of three way union to the outlet pipe line collect of flushing device through which the hot preservation oil (OM- 11) is delivered to compressors and the other end to air trolley. Refer Fig.6 for reference.
- Start pumping the preservation oil and the same time supply compressed air at pressure of 495 to 590 kPa by holding the outlet of the 'V' shaped three way union facing towards the compressor blades to spray in a mixture of air and oil into the gas flow bath of compressor.
- While supplying oil into the compressor, crank the engine exhaust.
- In case of engine cranking not feasible, preserve compressor by holding the outlet of the 'V' shaped three way union outlet facing all around the compressor inlet.
- For preserving the last stage of turbine to a full extent, deliver preservative oil (OM-11) under air pressure from the turbine side and crank the engine with the help of propeller.
- Confirm sufficient amount of oil drained from the combustion chamber drain point.

Conclusions and Recommendations

After certain hours of flying, aircraft. needs to be grounded for want of routine scheduled maintenance inspections. During these inspections, the engines are kept non-operative for a longer period. During this non- opera-

tive period, the engines are susceptible to extensive chronic corrosion. Over the long experience of operating the aircrafts, it has been observed that there is a necessity for an engine preservation system which will facilitate the testing of an aircraft engine using an external preservation rig for totally safest aircraft system which has zero material defect, zero breakdown and free from corrosion hazards while complying the safest material requirements.

Effect of engine performance parameters with respect to corrosion effects

- As per the engine heat balance sheet, there is 20-24% identified heat loss took place which reduces the performance of the aircraft engine.
- Engine does not run at designed economical speed conditions with respect to minimal brake specific fuel consumption and frictional power and maximum availability of brake power.
- Engine performance deterioration due to the non-compliance of optimum heat transfer requirements to useful power, cooling and exhaust system.
- 10-15% reduction in combustion efficiency because of incomplete combustion.
- The cruising air-fuel ratio and temperature in the gas turbine is be maintained as 60 :1 and 1250 deg C respectively. The net turbo propulsion thrust is equal to the sum of turbojet thrust plus propulsion thrust. During the longer maintenance period, corrosion takes place over the engine and associated pipelines. The corrosion hazards over the materials cause the reduction in engine lives with the resultant aircraft unsafe conditions. The metallurgical properties will vary in respect of corrosive materials with deficiency in resistant to the designed combustible temperature. Hence, engine deterioration takes place in improper maintenance of the air fuel ratio and temperature and thus causing engine seizure with the resultant curtails of output power and thermal efficiency. Due to the corrosion hazards, the net turbo propulsion thrust has been reduced considerably to 20%.

To avert this corrosion hazard problem of aircraft engines, a bogie hinge joint flushing device has been designed, fabricated and tested using the available resources after taking into consideration of this important engine external preservation requirements, layout of the turbo-propeller engine power plant and fuel supply sys-

tems. *This innovative external preservation rig has got multiple options coupled with internal preservation for preserving the engine components such as turbine, turbine blades, compressor, fuel nozzles, fuel system pipelines, diffuser, combustion cum mixing chamber, expansion nozzle and exhaust manifold during the course of long maintenance period.* The newly designed and developed external preservation rig has resulted in achieving the complete external preservation requirements of following categories of turbo-propeller engines.

- New/overhauled engines in storage and kept on expiry of preservation life
- Installed engine required to be removed for storage but can not be cranked or rotated
- Installed engines that are not in running condition/installation-seized engines.
- Uninstalled engine for defect investigation/defect rectification.
- Non operative unsafe engines

Acknowledgements

The author is thankful to Dr. A.K. Gupta, Director (EEA), Institution of Engineers (India) for awarding this project. He is also thankful to Lieutenant Commander S.N. Joglekar, Air Engineering Officer, Base Support Facility, Goa for providing necessary facilities. Special thanks are to Mr.G. Murugan, LEMAR, BSF (G), INS Hansa, Dabolim Air Port, Goa the required technical support.

References

1. "Technical Operating Instructions Manual and Maintenance", Manual of Aircraft IL-38
2. "Engine Operating Instructions Manual and Maintenance", Manual. Engine AI-20 M fitted on Aircraft IL-38.
3. "Engine Operating Instructions Manual and Maintenance", Manual of Industrial AVON Engines.
4. Saroe, A.S., "Thermal Engineering" Satya Prakasam, 880-884, 2000.