

Figure.2. Inclusion of 1-D Power Lookup Table in the Piston Engine Block.

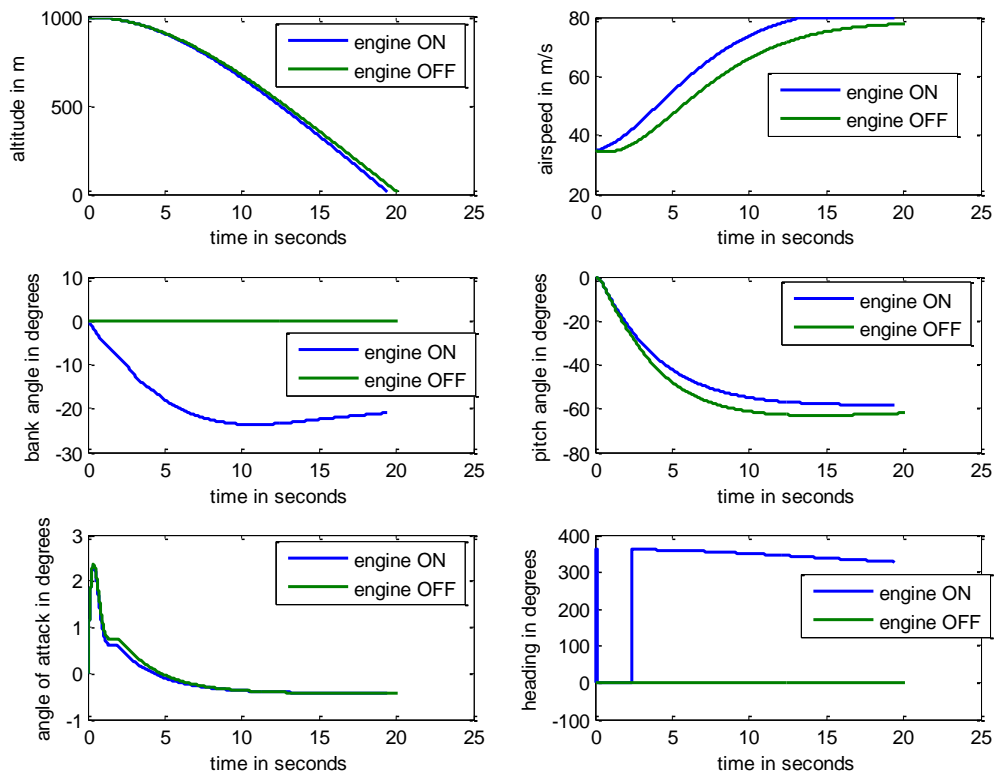

Figure.4. Open loop responses for the UAV model with engine ON and OFF.

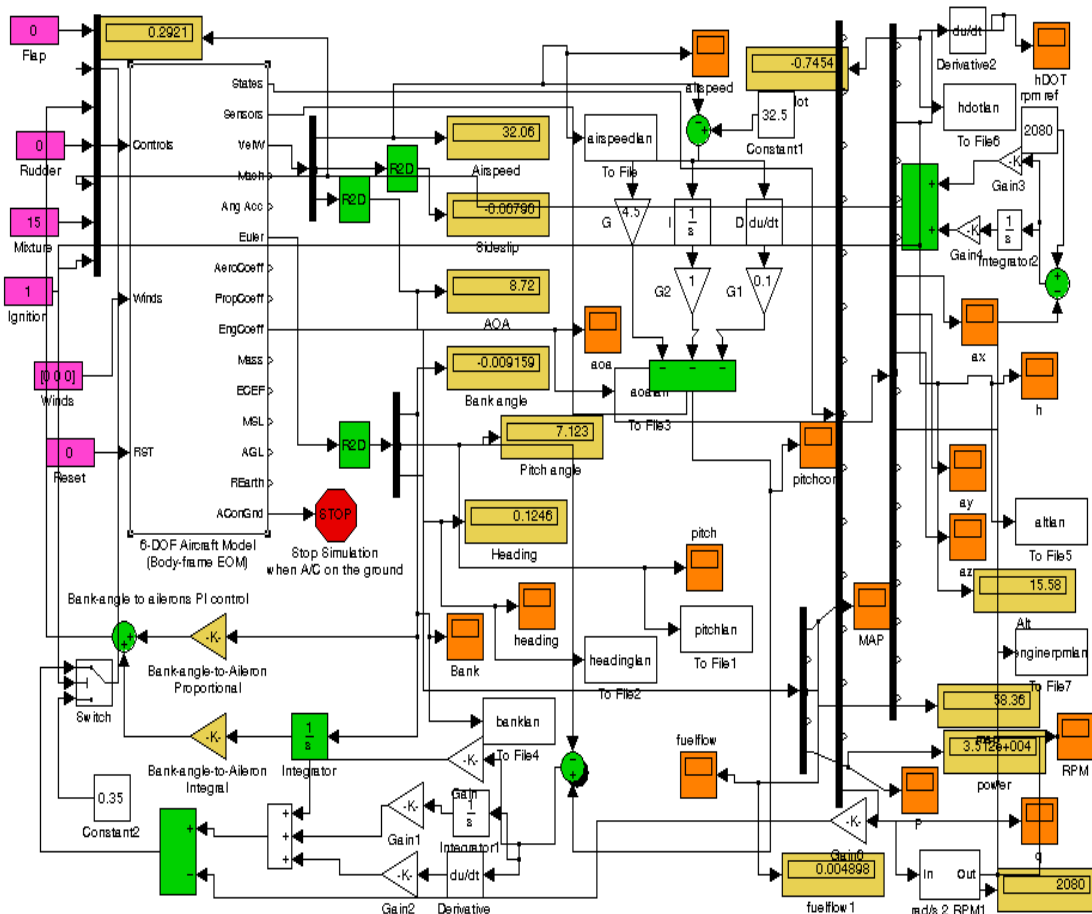

Figure.6. Simulink model for the landing phase of the UAV.

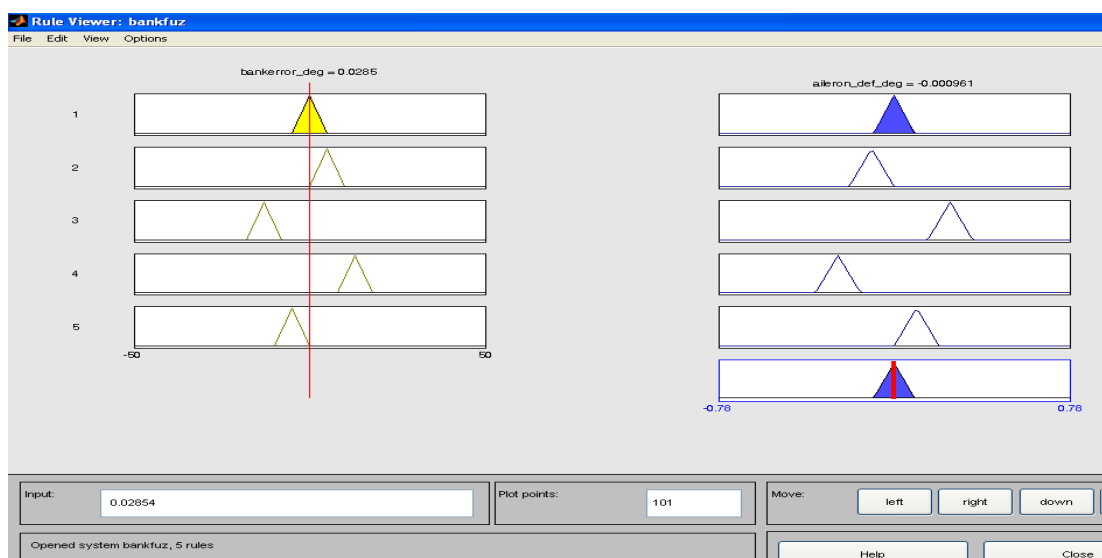

Figure.9. Rule Viewer for Bank to Aileron Fuzzy Logic Controller

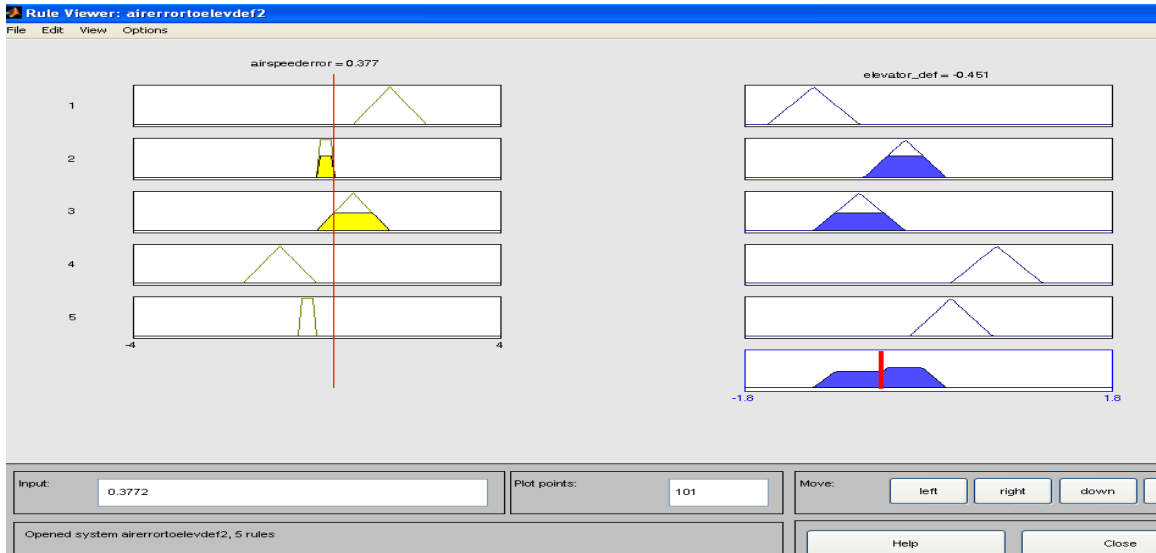

Figure.10. Rule Viewer for Airspeed to Elevator Fuzzy Logic Controller

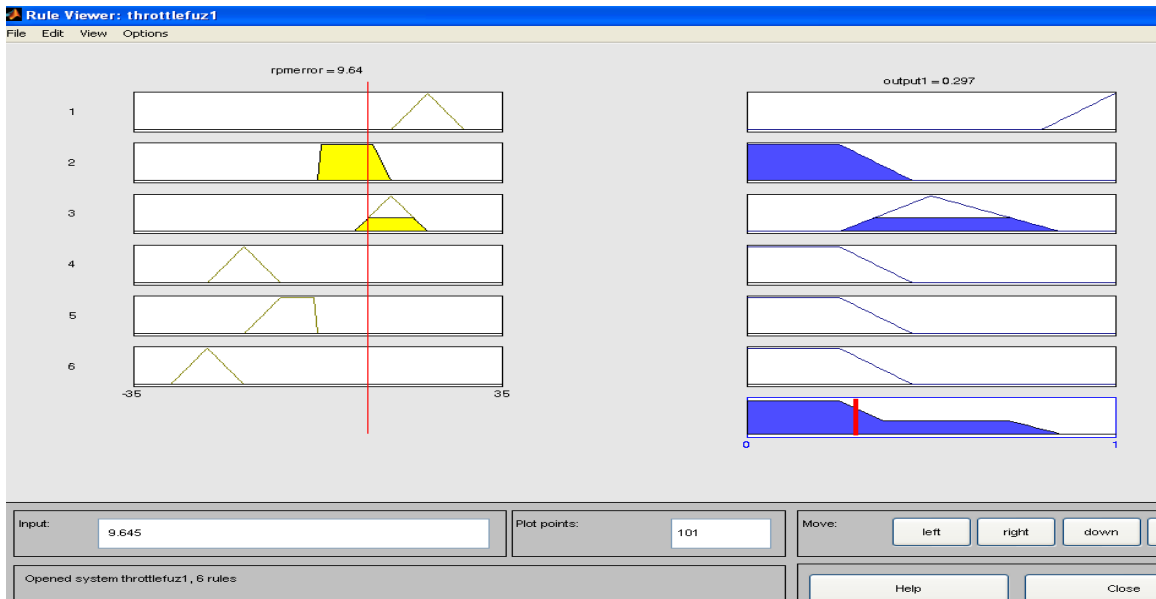

Figure.11. Rule Viewer For Engine RPM To Throttle Fuzzy Logic Controller.